

FKOM/CE 400V AC LUG ANSI - Elektrisch betätigte Absperrklappe DN 250:300

Absperrklappe LUG Version ANSI 150 mit elektrischem Antrieb 400 V AC.

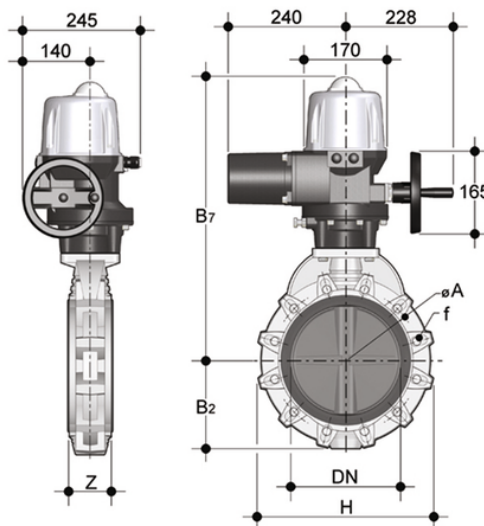

EPDM

Artikel	d	DN	product.detail.attribute.PN	product.detail.attribute.B[5:2]	H	Z	product.detail.attribute.[CS:Simbolo:Φ]A	product.detail.attribute.f	U
FKOALMEI810E	10"	250	6	210	405	114	362	7/8"	12
FKOALMEI812E	12"	300	6	245	475	114	431,8	7/8"	12

FKM

Artikel	d	DN	product.detail.attribute.PN	product.detail.attribute.B[5:2]	H	Z	product.detail.attribute.[CS:Simbolo:Φ]A	product.detail.attribute.f	U
FKOALMEI810F	10"	250	6	210	405	114	362	7/8"	12
FKOALMEI812F	12"	300	6	-	475	114	431,8	7/8"	12