

FKOV/CE 400V AC ANSI DN 250-300 - elektrisch betätigte Absperrklappe

ANSI-Absperrklappe mit elektrischem Antrieb 400 V AC.

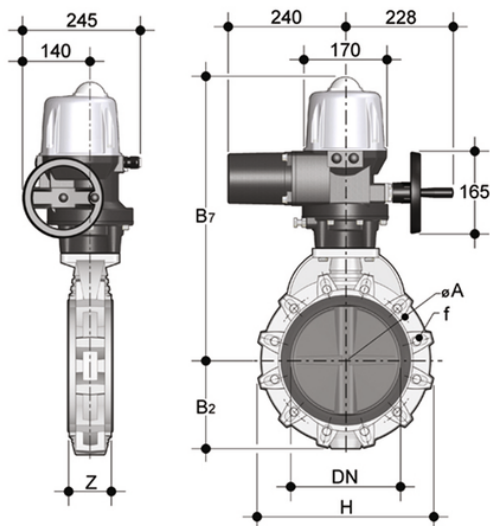

EPDM

Artikel	d	DN	product.detail.attribute.PN	product.detail.attribute.B2	H	Z	ΦA	product.detail.attribute.f	U	product.detail.attribute.
FKOAVEI810E	10"	250	10	210	405	114	362	25,4	12	555
FKOAVEI812E	12"	300	8	-	475	114	-	25,4	12	-

FKM

Artikel	d	DN	product.detail.attribute.PN	product.detail.attribute.B2	H	Z	ΦA	product.detail.attribute.f	U	product.detail.attribute.
FKOAVEI810F	10"	250	10	210	405	114	362	25,4	12	555
FKOAVEI812F	12"	300	8	-	475	114	-	25,4	12	-