

# FKOC/CE 400V AC ANSI - Elektrisch betätigte Absperrklappe DN 250:300

Absperrklappe nach ANSI 150 mit elektrischem Antrieb 400 V AC.

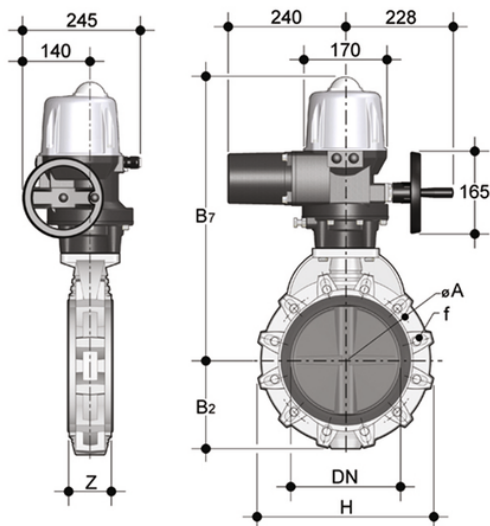

## EPDM

Artikel	d	DN	product.detail.attribute.PN	product.detail.attribute.B[5:2]	H	Z	product.detail.attribute.[CS:Simbolo:Φ]A	product.detail.attribute.f	U	p
FKOACEI810E	10"	250	10	210	405	114	362	25,4	12	5
FKOACEI812E	12"	300	8	245	475	114	431,8	25,4	12	6

## FKM

Artikel	d	DN	product.detail.attribute.PN	product.detail.attribute.B[5:2]	H	Z	product.detail.attribute.[CS:Simbolo:Φ]A	product.detail.attribute.f	U	p
FKOACEI810F	10"	250	10	210	405	114	362	25,4	12	5
FKOACEI812F	12"	300	8	245	475	114	431,8	25,4	12	6