

PE 11.94.511

TBE SDR33 - 90° T

90° T mit kurzem Schaft zum Stumpfschweißen SDR 33 - S16.

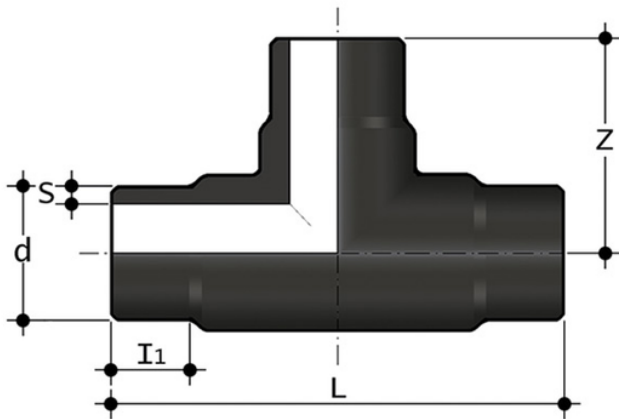

Artikel	d	L	Z	product.detail.attribute.[5:1]	product.detail.attribute.S	g
TBE33110	*110	215	105	30	3	664
TBE33125	*125	218	107	35	4	530
TBE33140	*140	253	125	20	4	1080
TBE33160	*160	270	140	40	5	1731
TBE33180	*180	310	150	45	6	2360
TBE33200	*200	340	170	45	6	3140
TBE33225	*225	440	220	48	7	4340
TBE33250	*250	438	215	52	8	7100
TBE33280	*280	500	243	65	9	8450
TBE33315	*315	535	270	77	10	10980
TBE33355	*355	674	347	96	11	16980
TBE33400	*400	680	340	90	12	23400
TBE33450	*450	890	450	130	14	33000
TBE33500	*500	895	450	130	15	33500