

PE 11.94.511

T45DE SDR11 - 45° T

45° T mit langem Schaft zum Stumpfschweißen SDR 11 - S5.

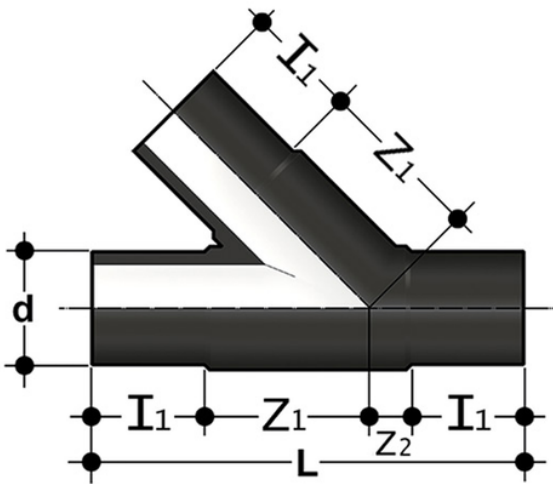

Artikel

T45DE11063

T45DE11075

T45DE11090

T45DE11110

T45DE11125

T45DE11160

T45DE11180

T45DE11200

T45DE11225