

VRUIV – Rückschlagventil DN 10:100

Rückschlagventil mit Überwurfverschraubungen zum Verkleben.

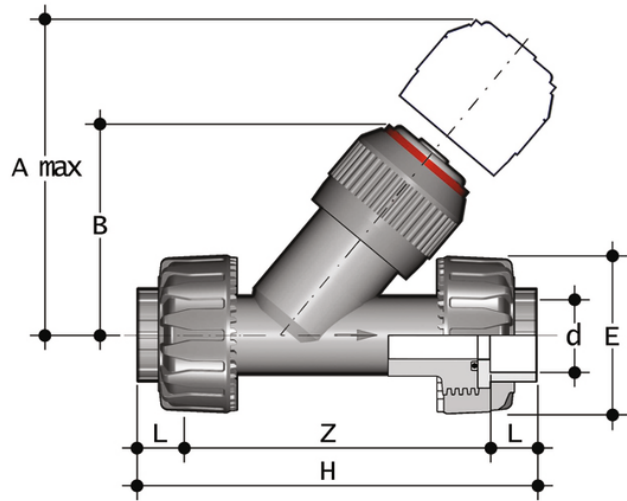

EPDM

Artikel	d	DN	product.detail.attribute.PN	product.detail.attribute.A max	B	product.detail.attribute.E	H	L	Z	Fig.	g
VRUIV016E	16	10	16	125	72	55	135	14	107	A	218
VRUIV020E	20	15	16	125	72	55	135	16	103	A	226
VRUIV025E	25	20	16	145	84	66	158	19	120	A	388
VRUIV032E	32	25	16	165	95	75	176	22	132	A	606
VRUIV040E	40	32	16	190	111	87	207	26	155	A	923
VRUIV050E	50	40	16	210	120	100	243	31	181	A	1335
VRUIV063E	63	50	16	240	139	120	298	38,2	221,6	A	2313

FKM

Artikel	d	DN	product.detail.attribute.PN	product.detail.attribute.A max	B	product.detail.attribute.E	H	L	Z	Fig.	g	product.detail.a ["d"]
VRUIV016F	16	10	16	125	72	55	135	14	107	A	218	-
VRUIV020F	20	15	16	125	72	55	135	16	103	A	226	-
VRUIV025F	25	20	16	145	84	66	158	19	120	A	388	-
VRUIV032F	32	25	16	165	95	75	176	22	132	A	606	-
VRUIV040F	40	32	16	190	111	87	207	26	155	A	923	-
VRUIV050F	50	40	16	210	120	100	243	31	181	A	1335	-



VRUIV - Rückschlagventil DN 10:100

Artikel	d	DN	product.detail.attribute.PN	product.detail.attribute.A max	B	product.detail.attribute.E	H	L	Z	Fig.	g	product.detail.a [["d"
VRUIV063F	-	-	-	-	-	-	-	-	-	-	-	63]

