

FKOC/CE 24V AC/DC - Elektrisch betätigte Absperrklappe DN 40:100

Absperrklappe mit elektrischem Antrieb 24 V AC/DC.

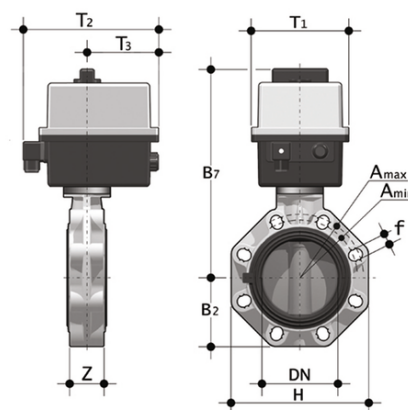
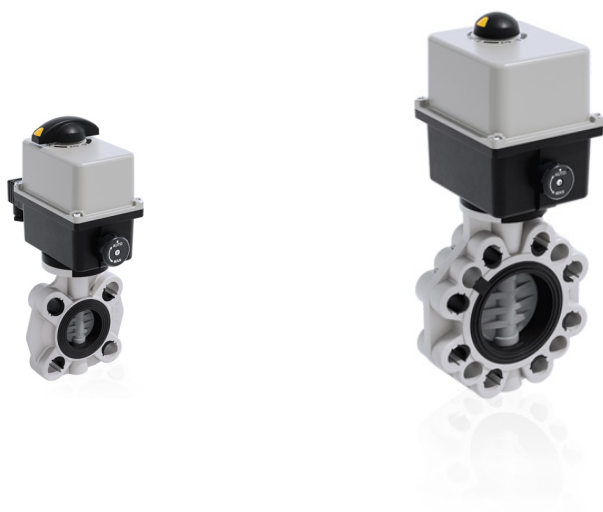

EPDM

Artikel	d	DN	product.detail.attribute.PN	product.detail.attribute.B2	H	Z	product.detail.attribute.Amin	product.detail.attribute.Amax
FKOCEL050E	50-1"1/2	40	16	60	132	33	99	109
FKOCEL063E	63-2"	50	16	70	147	43	115	125.5
FKOCEL075E	75-2"1/2	65	10	80	165	46	128	144
FKOCEL090E	90-3"	80	10	93	185	49	145	160
FKOCEL110E	110-4"	100	10	107	211	56	165	190

FKM

Artikel	d	DN	product.detail.attribute.PN	product.detail.attribute.B2	H	Z	product.detail.attribute.Amin	product.detail.attribute.Amax
FKOCEL050F	50-1"1/2	40	16	60	132	33	99	109
FKOCEL063F	63-2"	50	16	70	147	43	115	125.5
FKOCEL075F	75-2"1/2	65	10	80	165	46	128	144
FKOCEL090F	90-3"	80	10	93	185	49	145	160
FKOCEL110F	110-4"	100	10	107	211	56	165	190