

# FKOM/CE 24V AC/DC LUG ANSI - Elektrisch betätigte Absperrklappe DN 65:100

Absperrklappe LUG Version ANSI 150 mit elektrischem Antrieb 24 V AC/DC.

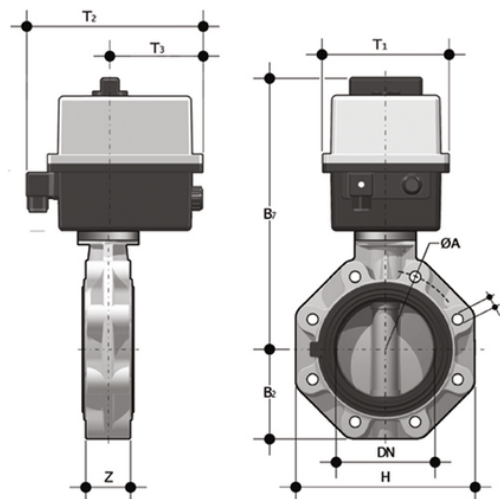

## EPDM

Artikel	d	DN	product.detail.attribute.PN	product.detail.attribute.B2	H	Z	ØA	product.detail.attribute.f	U	product.detail.attrit
FKOALMEL212E	2"1/2	65	10	80	165	46	139,7	5/8"	4	266
FKOALMEL300E	3"	80	10	93	185	49	152,4	5/8"	12	308
FKOALMEL400E	4"	100	10	107	211	56	190,5	5/8"	8	322

## FKM

Artikel	d	DN	product.detail.attribute.PN	product.detail.attribute.B2	H	Z	ØA	product.detail.attribute.f	U	product.detail.attrit
FKOALMEL212F	2"1/2	65	10	80	165	46	139,7	5/8"	4	266
FKOALMEL300F	3"	80	10	93	185	49	152,4	5/8"	12	308
FKOALMEL400F	4"	100	10	107	211	56	190,5	5/8"	8	322