

FKOM/CE 24V AC/DC LUG ANSI - Elektrisch betätigte Absperrklappe DN 250:300

Absperrklappe LUG Version ANSI 150 mit elektrischem Antrieb 24 V AC/DC.

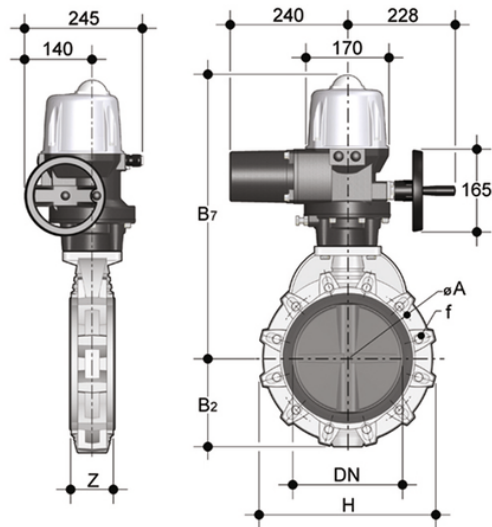

EPDM

Artikel	d	DN	product.detail.attribute.PN	product.detail.attribute.B2	H	Z	ΦA	product.detail.attribute.f	U	product.detail.attribute
FKOALMEE810E	10"	250	6	210	405	114	362	7/8"	12	597
FKOALMEE812E	12"	300	6	245	475	114	431.8	7/8"	12	654

FKM

Artikel	d	DN	product.detail.attribute.PN	product.detail.attribute.B2	H	Z	ΦA	product.detail.attribute.f	U	product.detail.attribute
FKOALMEE810F	10"	250	6	210	405	114	362	7/8"	12	597
FKOALMEE812F	12"	300	6	245	475	114	431.8	7/8"	12	654