

SRIF/SF – Ball check valve DN 15:50

Ball check valve with ends for socket welding, metric series.

The SR check valve allows the passage of fluid in a single direction.

- Connection system for weld joints
- PN10 **valve body made for PP-H injection moulding** and European Directive 2014/68/EU (PED) compliant for pressurised equipment. ISO 9393 compliant test requirements
- The valve can only be used with fluids with specific weight under 1,20 g/cm³
- **Sealing system with antiblow out design**
- Ball entirely in talc-filled PP
- Can be maintained with the valve body installed
- Can be **installed** in either a **vertical** (preferable) or **horizontal position**

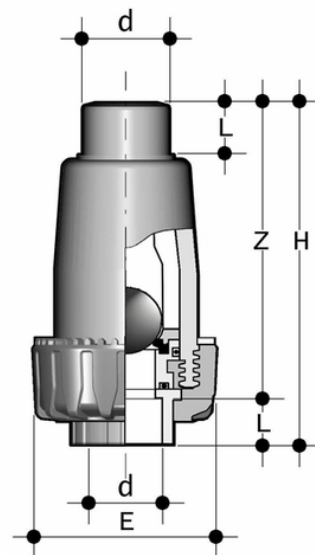

Reference	d	DN	PN	E	H	L	Z	g
SRIF020F0SF	20	15	16	54	104	16	88	150
SRIF025F0SF	25	20	16	65	125	19	106	260
SRIF032F0SF	32	25	16	74	148	22	126	390
SRIF040F0SF	40	32	16	86	171	26	145	600
SRIF050F0SF	50	40	16	98	189	31	158	820
SRIF063F0SF	63	50	16	119	222	38	184	1420

All information subject to change.

Please contact us on <https://www.aliasis.co.uk/get-in-touch> for further informations