

# PE 11.94.511

## Bend 90°, PE 100, SDR 11, short

- molded
- for heating element butt welding and IR welding
- GKE with 8 45° auxiliary markings for precise installation
- Continuous wall thickness
- R approx. 1 x de

Series of short and long fittings designed for conveying fluids under pressure for butt welding and electrofusion applications.

- Size range: d 12 ÷ d 800 (mm)
- Nominal pressure: SDR 17 (PN10) with water at 20 °C, SDR 11 (PN16) with water at 20 °C
- Temperature range: -40 °C ÷ 60 °C
- Coupling standards - Reference standards:
  - Welding: EN ISO 15494. Can be coupled to pipes according to EN ISO 15494
  - Flanging system: ISO 7005-1, EN 1092-1, EN ISO 15494, ANSI B16.5 cl.150
  - Construction criteria: UNI EN ISO 15494
  - Test methods and requirements: UNI EN ISO 15494
  - Installation criteria: DVS 2202-1, DVS 2207-1, UNI EN 12201- 3, UNI 10520, ISO 21307, UNI 10521, UNI EN 1555-3, ISO 4427- 3, ISO 4437-3
- Fitting material: PE-HD
- Seal material: EPDM, FKM

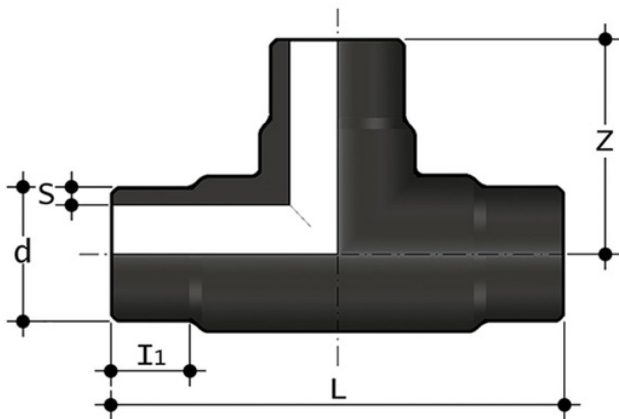

Reference	d	L	Z	h <sub>1</sub>	S	g
TBE11020	*20	76	38	11	1,9	21
TBE11025	*25	84	40	11	2,3	30
TBE11032	32	80	40	12	2,9	32
TBE11040	*40	90	45	11	3,7	67
TBE11050	50	124	62	25	4,6	119

All information subject to change.

Please contact us on <https://www.aliasis.co.uk/get-in-touch> for further informations



# PE 11.94.511

## Bend 90°, PE 100, SDR 11, short

Reference	d	L	Z	h	S	g
TBE11063	63	156	78	29	5,8	248
TBE11075	*75	153	75	19	6,8	394
TBE11090	*90	198	99	43	8,2	705
TBE11110	*110	254	127	55	10,0	1260
TBE11125	*125	254	125	52	11,4	1638
TBE11140	*140	314	153	65	12,7	2690
TBE11160	*160	322	161	58	14,6	3380
TBE11180	*180	430	214	94	16,4	5740
TBE11200	*200	438	219	90	18,2	7280
TBE11225	*225	452	226	76	20,5	9615
TBE11250	*250	450	227	68	22,7	10770
TBE17280	*280	530	265	87	25,4	15950
TBE11315	*315	570	285	88	28,6	21285
TBE11355	*355	698	349	103	32,2	31320
TBE11400	*400	730	363	105	36,3	39300
TBE11450	*450	837	419	137	40,9	65520
TBE11500	*500	930	465	159	45,4	73720

All information subject to change.

Please contact us on <https://www.aliaxis.co.uk/get-in-touch> for further informations

