

PE 11.94.511

Bend 90°, PE 100, SDR 11, short

- molded
- for heating element butt welding and IR welding
- GKE with 8 45° auxiliary markings for precise installation
- Continuous wall thickness
- R approx. 1 x de

Series of short and long fittings designed for conveying fluids under pressure for butt welding and electrofusion applications.

- Size range: d 12 ÷ d 800 (mm)
- Nominal pressure: SDR 17 (PN10) with water at 20 °C, SDR 11 (PN16) with water at 20 °C
- Temperature range: -40 °C ÷ 60 °C
- Coupling standards - Reference standards:
 - Welding: EN ISO 15494. Can be coupled to pipes according to EN ISO 15494
 - Flanging system: ISO 7005-1, EN 1092-1, EN ISO 15494, ANSI B16.5 cl.150
 - Construction criteria: UNI EN ISO 15494
 - Test methods and requirements: UNI EN ISO 15494
 - Installation criteria: DVS 2202-1, DVS 2207-1, UNI EN 12201- 3, UNI 10520, ISO 21307,UNI 10521, UNI EN 1555-3, ISO 4427- 3, ISO 4437-3
- Fitting material: PE-HD
- Seal material: EPDM, FKM

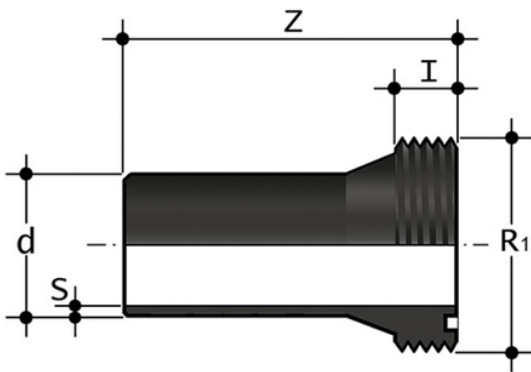

Reference	d	Z	I	R ₁	S	g
FBBEL11020	20	95	13	1"	1,9	24
FBBEL11025	25	95	13	1 1/4 "	2,3	40
FBBEL11032	32	95	14	1 1/2 "	2,9	54
FBBEL11040	40	95	16	2 "	3,7	60
FBBEL11050	50	95	18	2 1/4 "	4,6	116

All information subject to change.

Please contact us on <https://www.aliaxis.co.uk/get-in-touch> for further informations



PE 11.94.511

Bend 90°, PE 100, SDR 11, short

Reference	d	Z	l	R ₁	S	g
FBBEL11063	63	95	20	2 3/4 "	5,8	188

All information subject to change.

Please contact us on <https://www.aliaxis.co.uk/get-in-touch> for further informations

