

CKUIC/CP NO – Pneumatically actuated compact diaphragm valve DN 15

The new CK/CP valve represents the evolution of the CM/CP series, offering greater reliability, durability, and versatility. Designed for demanding industrial applications, it combines compactness, lightness, and high performance, ensuring safe and longlasting operation even in challenging environments.

The CM/CP is a pneumatically actuated valve with a compact structure and high flow capacity. The CM/CP is actuated by a dry running piston that can be actuated by all fluids or gases provided they are neutral and clean. The extremely compact structure of this valve permits easy installation even in highly confined spaces.

The new compact and light piston actuator in PP-GR makes the CK/CP the ideal choice for applications requiring very frequent valve operation and a long valve lifetime.

- High-visibility sealed position indicator for immediate and accurate visual feedback on valve status, enhancing operational safety and control.
- Compact and lightweight pistontype PP-GR actuator equipped with an anti-unscrewing system that prevents piston rotation. This design minimizes diaphragm wear, extends service life, and ensures maintenance-free operation.
- 90° adjustable compressed air inlets allow flexible alignment with pipeline connections or specific plant configurations, simplifying installation and integration.
- Unionized valve bodies available in PVC-U, PVC-C, PP-H, and PVDF, fully interchangeable with the previous CM/CP series. Designed according to EN-558 standards for dimensional compatibility and easy retrofitting.
- Diaphragm seal fully embedded within the valve body, ensuring optimal rubber compression without lateral expansion. This design enhances sealing performance, reduces wear, and improves long-term reliability.
- DualBlock® safety device prevents self-unscrewing of the actuator nut, ensuring secure and reliable operation even under dynamic process conditions.
- Circular rib integrated into the valve body enhances the diaphragm sealing system by promoting outward compression. This design maximizes sealing efficiency and reduces the risk of leakage under pressure.
- Valve body with union connection (PVC-U, PVC-C, PP-H, PVDF)
- No metal parts in contact with the fluid nor with the environment
- Dual block safety device to prevent self-unscrewing of the actuator nut
- Sealed optical position indicator
- Air inlets orientable every 90°
- Diaphragm seal fully embedded into the valve body
- Circular rib integrated into the valve body enhancing the effectiveness of the external sealing system
- Compatible with a wide range of chemicals (check on our Chemical Compatibility Guide - <https://www.aliaxis.it/en/tools-and-services/guide-to-chemical-compatibilities>)
- Suitable for industrial applications, dosing and sampling
- Compact and lightweight design
- Easy installation in tight spaces
- Average 10% increase flow capacity compared to the previous version

All information subject to change.

Please contact us on <https://www.aliaxis.co.uk/get-in-touch> for further informations

CKUIC/CP NO – Pneumatically actuated compact diaphragm valve DN 15

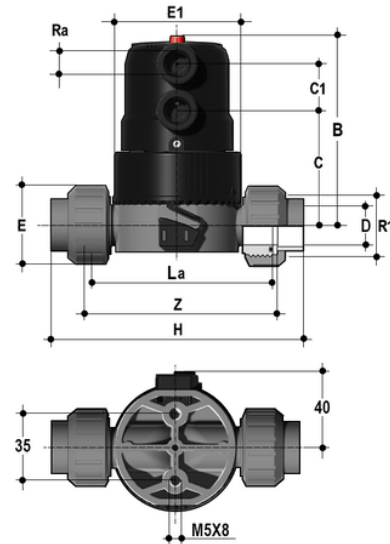

Reference	d	DN	PN	B	C	C ₁	E	E ₁	H	L[5:α]	R ₁	R[5:α]	Z	g
CKUIC/CP NO	20	15	6	97	59	24	41	66	129,5	90	1"	G 1/4"	97,5	335
CKUIC/CP NO	20	15	6	97	59	24	41	66	129,5	90	1"	G 1/4"	97,5	335