

USTM

Transition fitting HD-PE/steel with female thread

Transition fitting steel pipe USTM

- Gas and H₂
- Working pressure: MOP (gas) 5 bar
- Material: PE 100-RC and steel (EN 10278; EN 10277-3 - 11SMn30+C -, thread to EN 10226-1)
- Safety technology

Note:

Anchored the steel side non-detachable and non-rotatable in the PE.

Self-sealing, patented sealing geometry without elastomeric gasket for use in gas applications.

Other thread dimensions available on request.

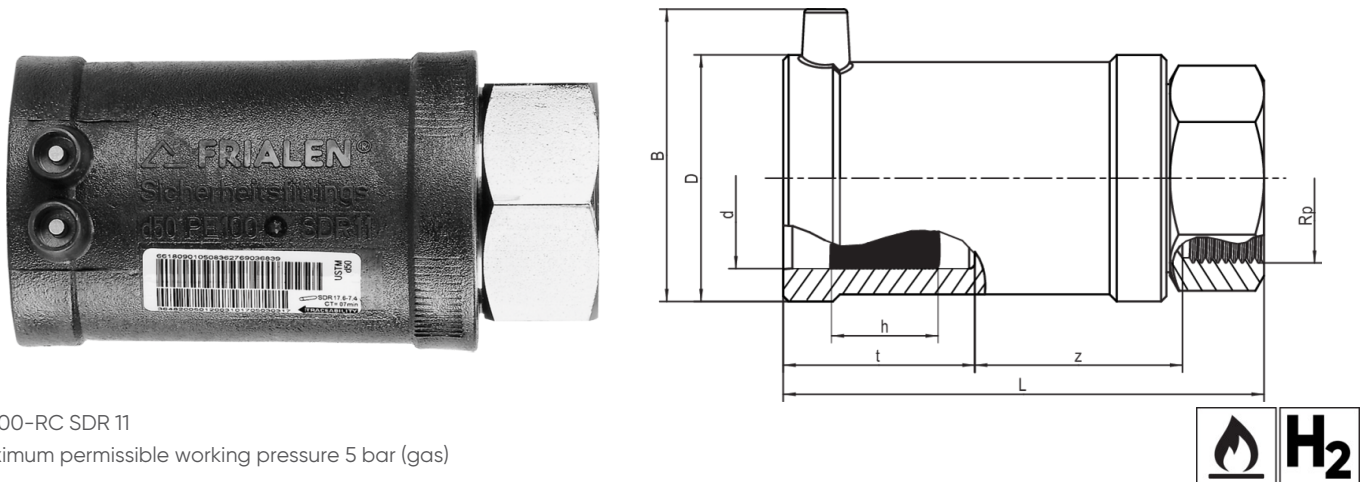

PE 100-RC SDR 11

Maximum permissible working pressure 5 bar (gas)

Reference	Diameter	Rp	B	D	h	L	t	z	Weight [kg]	BX	Pallet quantity
612570	32	1"	61	47	24	112	42	49	0,350	20	1080
612572	40	1 1/4"	70	58	30	121	46	53	0,510	20	800
612574	50	1 1/2"	80	70	30	136	53	60	0,650	15	600
612576	63	2"	94	84	35	141	53	61	1,020	10	400

USTM

Transition fitting HD-PE/steel with female thread

Areas of Application

FRIALEN-Transition Fittings USTM are threaded joints as an adaptor from a metal pipe with external thread to a HD-PE pipe. Joint on the part of HD-PE by FRIALEN-Coupler.

Other thread dimensions on request

FRIALEN safety fittings can be fused with SDR11 - SDR17,6 pipes, minimum wall thickness $s_{\text{minimum}} \geq 3$ mm. Other levels of SDR can be processed on request. Please note the mandatory labels directly on the product. DVGW test mark issued: DV-7501AU2256.

Assembly Instructions

The threaded component must be held with a spanner to prevent it twisting in the HD-PE component. The fusion of the HD-PE side takes place by FRIALEN-fusing – leakproof and longitudinally strong.

The installation of the steel and the HD-PE side has to be prepared according to the general installation instructions (see "Transition Fittings with threaded connection" in "Assembly Instructions" for "FRIALEN-Safety Fittings for house connections and distribution pipes up to d 225"). This involves removing the oxide skin and cleaning the pipe ends.

Good reasons for using the FRIALEN-USTM:

- Compact construction
- HD-PE side with exposed heating element for optimal heat transfer
- Cold zones at the end to prevent the flow of molten material
- No holding clamps required
- Large insertion depth, extra wide fusion zones
- Steel end permanently anchored in the HD-PE and will not distort
- Self sealing patented sealing geometry without elastomer seal
- Additional barcode for tracing back the fitting (Traceability-Coding)