

UAM

Transition fitting HD-PE spigot/brass with female thread

Universal transition adaptor brass pipe UAM

- Water and gas
- Working pressure: MOP (gas) 5 bar, PFA (water) 16 bar
- Material: PE 100 and brass [CW617N / CW612N, ISO 228 thread]

Note:

The brass side is anchored non-detachable and non-rotatable in the PE.

Installation independent of position possible.

For use in the water and gas sector.

Other thread dimensions and materials on request.

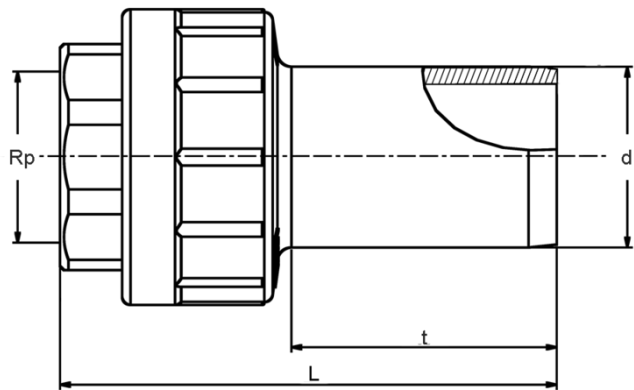

PE 100 SDR 11

Maximum permissible working pressure 16 bar (water) / 5 bar (gas)



Reference	Diameter	Rp	L	t	SW	Weight [kg]	BX	Pallet quantity
616615	20	1/2"	79	41	26	0,080	80	4800
616616	25	3/4"	77	44	32	0,120	60	3600
616156	32	1"	88	47	40	0,190	36	2160
616157	40	1 1/4"	100	56	49	0,290	20	1200
616158	50	1 1/2"	102	57	55	0,350	16	960
616621	63	1 1/2"	115	63	55	0,450	10	600
616159	63	2"	120	63	67	0,550	10	600
616665	75	2 1/2"	128	70	82	0,720	10	300
616623	90	3"	144	78	94	1,100	10	240
616624	110	4"	161	87	120	1,850	6	180
616666	125	4"	161	92	120	1,990	4	120

Transition fitting HD-PE spigot/brass with female thread

Areas of Application

The FRIALEN Universal Adapter UAM serves to connect metal construction parts which have a screwed connection e.g. valves with an HD-PE connection pipe. Suitable for gas and water supply or for industrial applications. The version with PE spigot end allows for assembly regardless of location and the homogenous fusion connection with all suitable FRIALEN fittings (exception of FRIALONG- and FRIASTOPP-Long couplers).

The threaded joint is according ISO 7-1.

Assembly Instructions

Usually the screw connection needs to be assembled first as assembly related torsion forces should not bear down on the connected PE pipe. The tightening forces must be introduced via the specially designed wrench area.

The fusion of the PE spigot end with a FRIALEN coupler takes place by using FRIALEN fusion process – leakproof and longitudinally strong.

The installation is according to the general installation instruction (see "Transition Fittings with threaded connection" in "Assembly Instructions" for "FRIALEN-Safety Fittings for house connections and distribution pipes up to d 225"). This involves removing the oxide layer and cleaning the pipe ends.

Please note the mandatory labels directly on the product.

DVGW test mark issued with reg. no.:

- DW-7511CR0155
- DG-7521CR0172

The brass female thread is made of the material CW612N or CW617N.

Other brass materials available on request.

Good reasons for using the FRIALEN-Universal Adapter UAM:

- PE 100 spigot end – quality controlled
- Tested and quality controlled brass quality
- Assembly regardless of location, high degree of flexibility due to separate fusion of PE spigot end
- May be used with all FRIALEN fittings of identical dimensions (exception of FRIALONG- and FRIASTOPP-Long couplers)
- Universal combination option with the FRIALEN range
- HD-PE side with spigot end for processing without holding device, designed for FRIALEN couplers
- Pull-proof connection
- Brass side tightly connected with PE spigot end, safe from distortion
- Compact construction
- Additional barcode for tracing back the fitting (Traceability-Coding).
- Oxidic layer may be removed from PE spigot end using scraper tools