

VKDOM – VKDOAM – DUAL BLOCK® 2-way ball valve DN 65:100

VKDOM: DUAL BLOCK® 2-way ball valve with fixed flanges, drilled EN/ISO/DIN PN10/16. Face to face according to EN 558-1.

VKDOAM: DUAL BLOCK® ball valve with ANSI B16.5 cl.150#FF fixed flanges *.

FIP has developed a VKD DUAL BLOCK® ball valve to introduce a high reference standard in thermoplastic valve design. VKD is a True Union ball valve that meets the most stringent needs required by industrial applications. This valve is also equipped with a customisable Labelling System.

- HIPVC ergonomic multifunctional handle for quick operation, **lock and graduated adjustment in 10 positions**. Possibility of inhibiting rotation with a lock
- Customisable Labelling System: LCE module made of a transparent protection plug and **customisable tag holder** using the LSE set (available as accessory). The customisation lets you identify the valve on the system according to specific needs
- **DUAL BLOCK®** patented lock system that ensures union nut tightening hold even in severe conditions such as vibrations or heat dilation
- **Double stem** with double O-Rings for ball centring and operating torque reduction
- Machined high surface finish ball that guarantees a smooth operation and increased reliability
- Connection system for solvent weld, threaded and flanged joints
- Patented **SEAT STOP®** ball carrier system that lets you micro-adjust seals and minimise axial force effects
- Easy radial dismounting allowing quick replacement of O-rings and ball seats without any need for tools
- **PN16 True Union valve body** made for rigid PVC-U injection moulding equipped with built-in bores for actuation. ISO 9393 compliant test requisites
- Option of dismounting downstream pipes with the valve in the closed position
- **Full bore ball** with high surface finish
- **Integrated bracket** for valve anchoring
- Possibility of installing a manual reducer or pneumatic and/or electric actuators by applying an ISO standard bore PP-GR flange
- **STAINLESS steel co-moulded stem**, with square section as per ISO 5211
- Possibility to have handle with integrated LSQT limit micro switch, even as a retrofit in existing installations

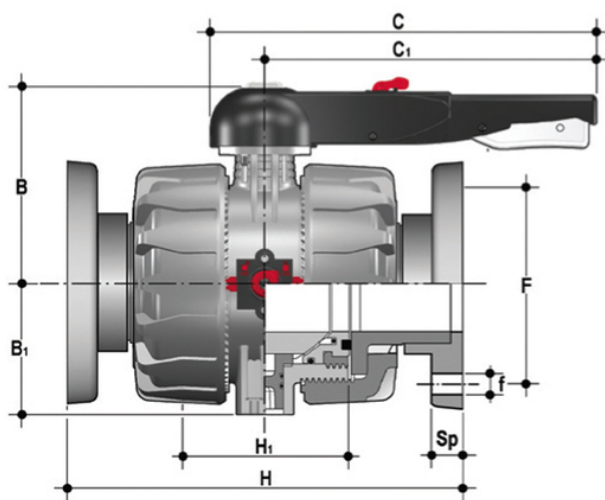

All information subject to change.

Please contact us on <https://www.aliaxis.co.uk/get-in-touch> for further informations

VKDOM - VKDOAM - DUAL BLOCK® 2-way ball valve DN 65:100

EPDM

Reference	d	DN	PN	B	B ₁	C	C ₁	F	f	H	H1	Sp	U	g
VKDOM075E	75	65	10	164	87	225	175	145	17	290	133	24	4	4500
VKDOM090E	90	80	10	177	105	327	272	160	17	310	149	25	8	6455
VKDOM110E	110	100	10	195	129	385	330	180	17	350	167	25	8	9090

FKM

Reference	d	DN	PN	B	B ₁	C	C ₁	F	f	H	H1	Sp	U	g
VKDOM075F	75	65	10	164	87	225	175	145	17	290	133	24	4	4500
VKDOM090F	90	80	10	177	105	327	272	160	17	310	149	25	8	6455
VKDOM110F	110	100	10	195	129	385	330	180	17	350	167	25	8	9090

All information subject to change.

Please contact us on <https://www.aliaxis.co.uk/get-in-touch> for further informations