

# SVUIV - Relief valve DN 15:25

Relief valve with unionised metric plain socket ends for solvent welding.

The SV relief valve is used in the presence of batching pumps to prevent an undesired increase in pressure and maintain constant operating pressure.

- Whenever upstream pressure exceeds the level at which the spring is calibrated by the user, the valve will open under the pressure of the fluid, lowering pressure on the line and thereby protecting the components in the system. The valve automatically closes again when the operating pressure on the piston drops to the value to which the spring is calibrated
- Metal parts isolated from fluid and from the environment
- Designed to permit easy installation and adjustment

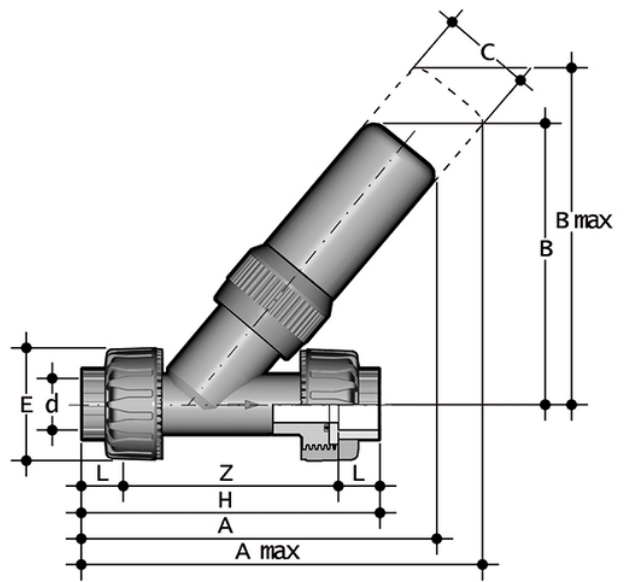

## EPDM

Reference	d	DN	A	A max	B	B max	C	E	H	L	Z	g
SVUIV020E	20	15	153	193	118	170	34	55	135	16	103	391
SVUIV025E	25	20	191	271	150	220	40	66	158	19	120	633
SVUIV032E	32	25	226	296	175	230	48	75	176	22	132	1106

## FKM

Reference	d	DN	A	A max	B	B max	C	E	H	L	Z	g
SVUIV020F	20	15	153	193	118	170	34	55	135	16	103	391
SVUIV025F	25	20	191	271	150	220	40	66	158	19	120	633
SVUIV032F	32	25	226	296	175	230	48	75	176	22	132	1106

All information subject to change.

Please contact us on <https://www.aliaxis.co.uk/get-in-touch> for further informations