

VRUIM - Check valve DN 15:80

Check valve with female union ends for socket welding, metric series.

The VR is an angle seat check valve with weighted PP-H piston that allows the passage of fluid in one direction only.

- Connection system for weld, threaded and flanged joints
- **No metal parts in contact with the fluid**
- **Piston with counterweight** able to work with high intensity fluid
- Limited pressure drop. Only minimum back pressure is required for the hermetic seal
- **Valve material compatibility** (PP-H) with water conveyance, drinking water and other food substances according to **current regulations**
- Can be maintained with the valve body installed

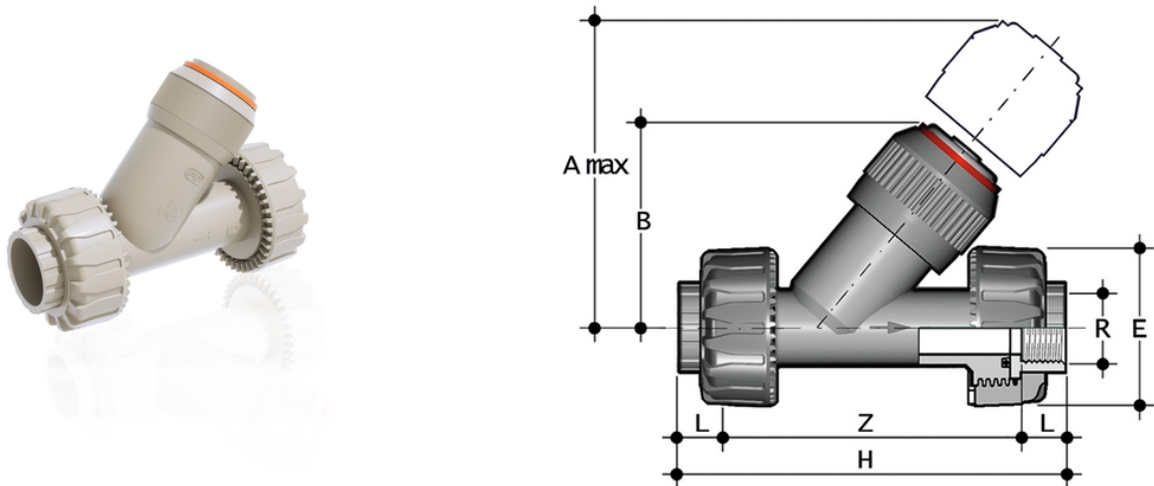

EPDM

Reference	d	DN	PN	A max	B	E	H	Z	g
VRUIM020E	20	15	10	125	71	55	138	109	165
VRUIM025E	25	20	10	145	83	66	157	125	227
VRUIM032E	32	25	10	165	94	74	179	143	380
VRUIM040E	40	32	10	190	109	86	205	164	645
VRUIM050E	50	40	10	210	119	99	244	197	915
VRUIM063E	63	50	10	240	143	120	294	239	1555

FKM

Reference	d	DN	PN	A max	B	E	H	Z	g
VRUIM020F	20	15	10	125	71	55	138	109	165
VRUIM025F	25	20	10	145	83	66	157	125	227

All information subject to change.

Please contact us on <https://www.aliaxis.co.uk/get-in-touch> for further informations



VRUIM - Check valve DN 15:80

Reference	d	DN	PN	A max	B	E	H	Z	g
VRUIM032F	32	25	10	165	94	74	179	143	380
VRUIM040F	40	32	10	190	109	86	205	164	645
VRUIM050F	50	40	10	210	119	99	244	197	915
VRUIM063F	63	50	10	240	143	120	294	239	1555

All information subject to change.

Please contact us on <https://www.aliasis.co.uk/get-in-touch> for further informations

