

VRIM – Check valve DN 15:80

Check valve with female ends for socket welding, metric series.

The VR is an angle seat check valve with weighted PP-H piston that allows the passage of fluid in one direction only.

- Connection system for weld, threaded and flanged joints
- **No metal parts in contact with the fluid**
- **Piston with counterweight** able to work with high intensity fluid
- Limited pressure drop. Only minimum back pressure is required for the hermetic seal
- **Valve material compatibility** (PP-H) with water conveyance, drinking water and other food substances according to **current regulations**
- Can be maintained with the valve body installed

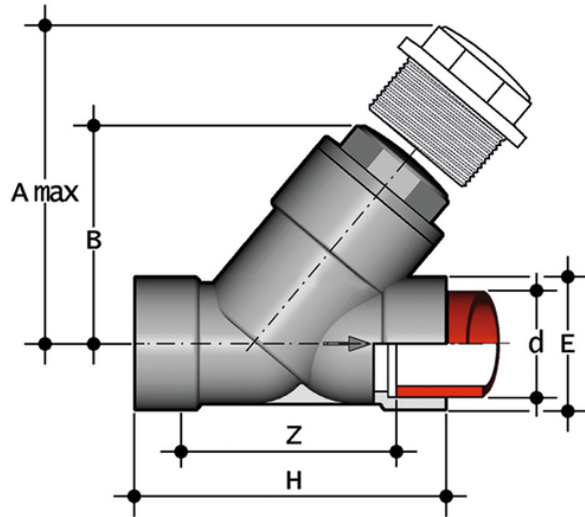

EPDM

Reference	d	DN	PN	A max	B	E	H	K	Z	g
VRIM075E	75	65	6	300	176	103	241	96	179	2450
VRIM090E	90	80	4	325	192	115	260	105	189	3130

FKM

Reference	d	DN	PN	A max	B	E	H	K	Z	g
VRIM075F	75	65	6	300	176	103	241	96	179	2450
VRIM090F	90	80	4	325	192	115	260	105	189	3130

All information subject to change.

Please contact us on <https://www.aliaxis.co.uk/get-in-touch> for further informations