

VRUFM – Check valve DN 15:80

Check valve with BSP threaded female union ends.

The VR is an angle seat check valve with weighted PP-H piston that allows the passage of fluid in one direction only.

- Connection system for weld, threaded and flanged joints
- **No metal parts in contact with the fluid**
- **Piston with counterweight** able to work with high intensity fluid
- Limited pressure drop. Only minimum back pressure is required for the hermetic seal
- **Valve material compatibility** (PP-H) with water conveyance, drinking water and other food substances according to **current regulations**
- Can be maintained with the valve body installed

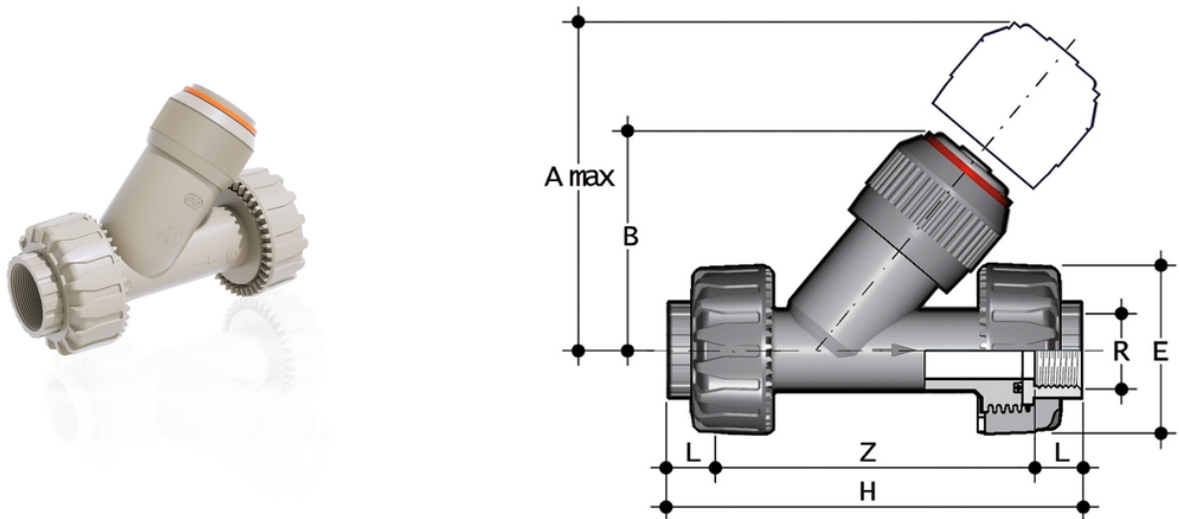

EPDM

Reference	R	DN	PN	A max	B	E	H	Z	g
VRUFM012E	1/2"	15	10	125	71	55	143	113	165
VRUFM034E	3/4"	20	10	145	83	65	160	127	227
VRUFM100E	1"	25	10	165	94	74	183	145	380
VRUFM114E	1" 1/4	32	10	190	109	86	214	171	645
VRUFM112E	1" 1/2	40	10	210	119	99	235	192	915
VRUFM200E	2"	50	10	240	143	120	285	234	1555

FKM

Reference	R	DN	PN	A max	B	E	H	Z	g
VRUFM012F	1/2"	15	10	125	71	55	143	113	165
VRUFM034F	3/4"	20	10	145	83	65	160	127	227

All information subject to change.

Please contact us on <https://www.aliasis.co.uk/get-in-touch> for further informations



VRUFM – Check valve DN 15:80

Reference	R	DN	PN	A max	B	E	H	Z	g
VRUFM100F	1"	25	10	165	94	74	183	145	380
VRUFM114F	1" 1/4	32	10	190	109	86	214	171	645
VRUFM112F	1" 1/2	40	10	210	119	99	235	192	915
VRUFM200F	2"	50	10	240	143	120	285	234	1555

All information subject to change.

Please contact us on <https://www.aliasis.co.uk/get-in-touch> for further informations

