

VRUOAM – Check valve DN 15:80

Check valve with union ends and fixed flanges, drilled ANSI B16.5 cl.150 #FF.

The VR is an angle seat check valve with weighted PP-H piston that allows the passage of fluid in one direction only.

- Connection system for weld, threaded and flanged joints
- **No metal parts in contact with the fluid**
- **Piston with counterweight** able to work with high intensity fluid
- Limited pressure drop. Only minimum back pressure is required for the hermetic seal
- **Valve material compatibility** (PP-H) with water conveyance, drinking water and other food substances according to **current regulations**
- Can be maintained with the valve body installed

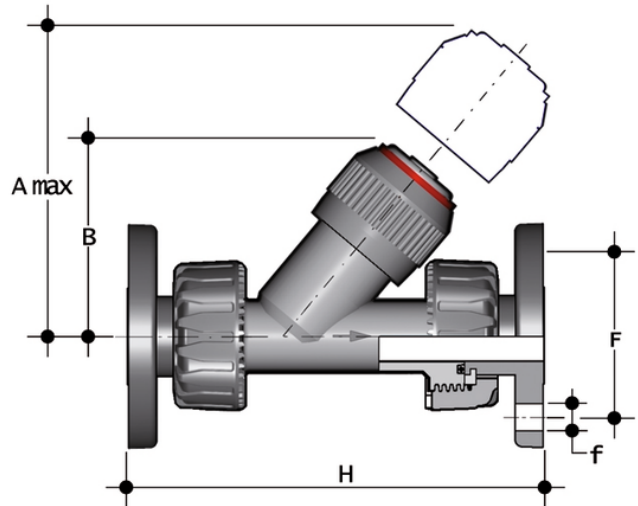

EPDM

Reference	Size	DN	PN	A max	B	F	f	H	g
VRUOAM012E	1/2"	15	10	125	72	60	16	175	265
VRUOAM034E	3/4"	20	10	145	84	70	16	214	327
VRUOAM100E	1"	25	10	165	95	79	16	237	480
VRUOAM114E	1 1/4"	32	10	190	111	89	16	253	795
VRUOAM112E	1 1/2"	40	10	210	120	98	16	289	1065
VRUOAM200E	2"	50	10	240	139	121	19	333	1705

FKM

Reference	Size	DN	PN	A max	B	F	f	H	g
VRUOAM012F	1/2"	15	10	125	72	60	16	175	265
VRUOAM034F	3/4"	20	10	145	84	70	16	214	327

All information subject to change.

Please contact us on <https://www.aliaxis.co.uk/get-in-touch> for further informations



VRUOAM – Check valve DN 15:80

Reference	Size	DN	PN	A max	B	F	f	H	g
VRUOAM100F	1"	25	10	165	95	79	16	237	480
VRUOAM114F	1"1/4	32	10	190	111	89	16	253	795
VRUOAM112F	1"1/2	40	10	210	120	98	16	289	1065
VRUOAM200F	2"	50	10	240	139	121	19	333	1705

All information subject to change.

Please contact us on <https://www.aliasis.co.uk/get-in-touch> for further informations

