

VROAM – Check valve DN 15:80

Check valve with steel core backing ring, PP/FRP coated, drilled ANSI B16.5 cl.150 #FF.

The VR is an angle seat check valve with weighted PP-H piston that allows the passage of fluid in one direction only.

- Connection system for weld, threaded and flanged joints
- **No metal parts in contact with the fluid**
- **Piston with counterweight** able to work with high intensity fluid
- Limited pressure drop. Only minimum back pressure is required for the hermetic seal
- **Valve material compatibility** (PP-H) with water conveyance, drinking water and other food substances according to **current regulations**
- Can be maintained with the valve body installed

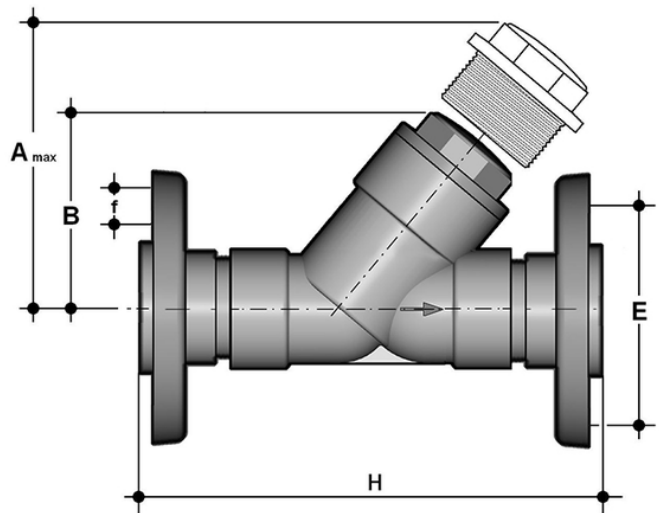

EPDM

Reference	d - Size	DN	PN	A max	B	F	f	H	g
VROAM075E	75 - 2"1/2	65	6	300	176	139,7	18	356	5595
VROAM090E	90 - 3"	80	4	325	192	152,4	18	404	6385
VROAM212E									
VROAM300E									

FKM

Reference	d - Size	DN	PN	A max	B	F	f	H	g
VROAM075F	75 - 2"1/2	65	6	300	176	139,7	18	356	5595
VROAM090F	90 - 3"	80	4	325	192	152,4	18	404	6385
VROAM212F									
VROAM300F									

All information subject to change.

Please contact us on <https://www.aliaxis.co.uk/get-in-touch> for further informations