

RVUFM – Sediment strainer DN 15:100

Sediment strainer with BSP threaded female union ends.

The RV Sediment strainer limits the passage of any solid particles present in the fluid by means of a strainer.

- Connection system for weld, threaded and flanged joints
- **Strainer** assembled on an **easily removed support** that facilitates cleaning or replacement
- **Valve material compatibility** (PP-H) with water conveyance, drinking water and other food substances according to **current regulations**
- Can be maintained with the valve body installed

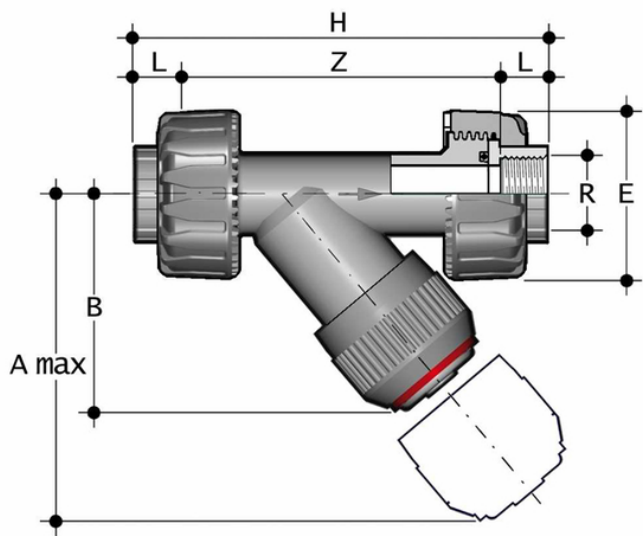

EPDM

Reference	R	DN	PN	A max	B	E	H	Z	Fig.	g
RVUFM012E	1/2"	15	10	125	71	55	142	112	A	148
RVUFM034E	3/4"	20	10	145	83	66	159	126	A	195
RVUFM100E	1"	25	10	165	94	74	183	145	A	297
RVUFM114E	1" 1/4	32	10	190	109	86	214	171	A	475
RVUFM112E	1" 1/2	40	10	210	119	99	235	192	A	675
RVUFM200E	2"	50	10	240	143	120	285	234	A	1100

FKM

Reference	R	DN	PN	A max	B	E	H	Z	Fig.	g
RVUFM012F	1/2"	15	10	125	71	55	142	112	A	148
RVUFM034F	3/4"	20	10	145	83	66	159	126	A	195
RVUFM100F	1"	25	10	165	94	74	183	145	A	297

All information subject to change.

Please contact us on <https://www.aliaxis.co.uk/get-in-touch> for further informations



RVUFM – Sediment strainer DN 15:100

Reference	R	DN	PN	A max	B	E	H	Z	Fig.	g
RVUFM114F	1" 1/4	32	10	190	109	86	214	171	A	475
RVUFM112F	1" 1/2	40	10	210	119	99	235	192	A	675
RVUFM200F	2"	50	10	240	143	120	285	234	A	1100

All information subject to change.

Please contact us on <https://www.aliaxis.co.uk/get-in-touch> for further informations

