

RVUOAM - Sediment strainer DN 15:100

Sediment strainer with female union ends and fixed flanges, drilled ANSI B16.5 cl.150 #FF.

The RV Sediment strainer limits the passage of any solid particles present in the fluid by means of a strainer.

- Connection system for weld, threaded and flanged joints
- **Strainer** assembled on an **easily removed support** that facilitates cleaning or replacement
- **Valve material compatibility** (PP-H) with water conveyance, drinking water and other food substances according to **current regulations**
- Can be maintained with the valve body installed

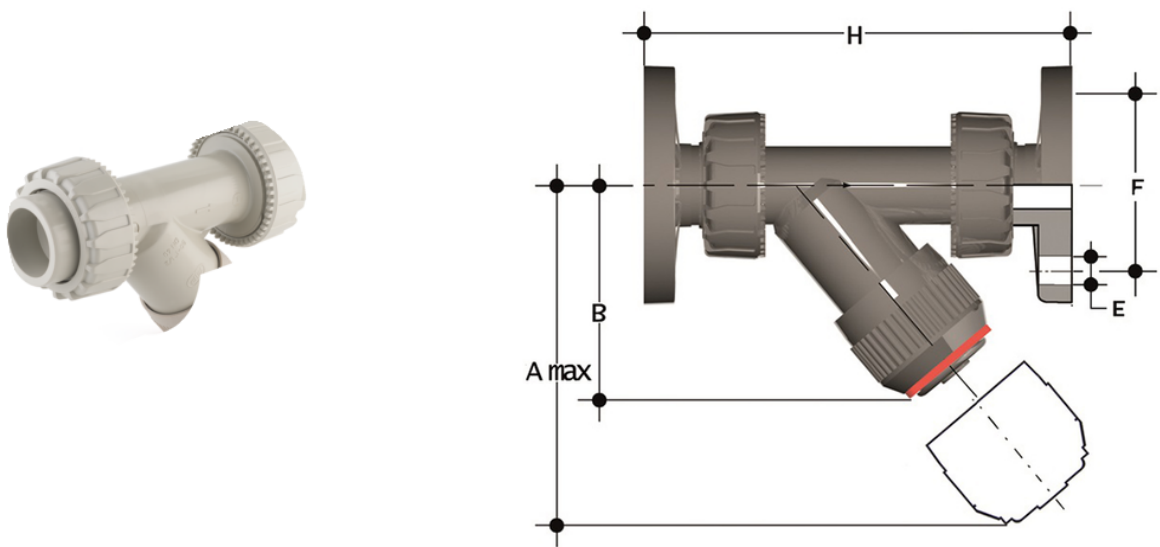

EPDM

Reference	d	DN	PN	A max	B	F	f	H	g
RVUOAM012E	1/2"	15	10	125	72	60	16	175	248
RVUOAM034E	3/4"	20	10	145	84	70	16	214	295
RVUOAM100E	1"	25	10	165	95	79	16	237	397
RVUOAM114E	1 1/4"	32	10	190	111	89	16	253	625
RVUOAM112E	1 1/2"	40	10	210	120	98	16	289	825
RVUOAM200E	2"	50	10	240	139	121	19	333	1250

FKM

Reference	d	DN	PN	A max	B	F	f	H	g
RVUOAM012F	1/2"	15	10	125	72	60	16	175	248
RVUOAM034F	3/4"	20	10	145	84	70	16	214	295
RVUOAM100F	1"	25	10	165	95	79	16	237	397

All information subject to change.

Please contact us on <https://www.aliaxis.co.uk/get-in-touch> for further informations



RVUOAM - Sediment strainer DN 15:100

Reference	d	DN	PN	A max	B	F	f	H	g
RVUOAM114F	1"1/4	32	10	190	111	89	16	253	625
RVUOAM112F	1"1/2	40	10	210	120	98	16	289	825
RVUOAM200F	2"	50	10	240	139	121	19	333	1250

All information subject to change.

Please contact us on <https://www.aliasis.co.uk/get-in-touch> for further informations

