

RVUAC - Sediment strainer DN 15:50

Sediment strainer with female union ends for solvent welding, ASTM series.

The RV Sediment strainer limits the passage of any solid particles present in the fluid by means of a strainer.

- Connection system for solvent weld, threaded and flanged joints
- **Strainer** mounted on an easily removed **support** that facilitates the cleaning or replacement
- **Valve material compatibility** (PVC-C) with water conveyance, drinking water and other food substances according to **current regulations**
- Can be maintained with the valve body installed

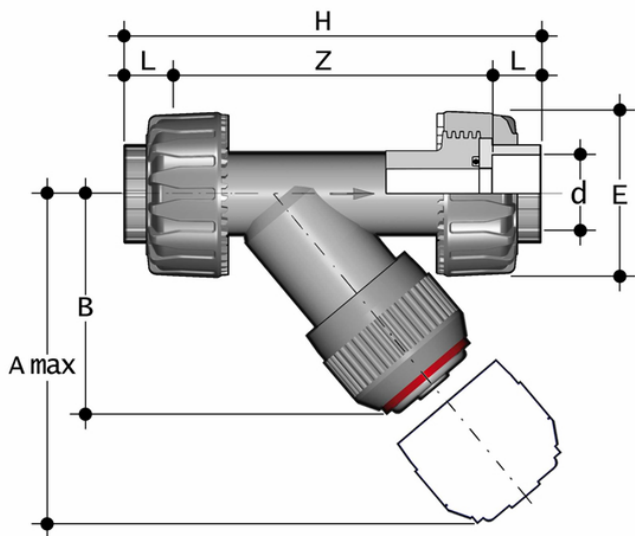

EPDM

Reference	d	DN	PN	A max	B	E	H	L	Z	g
RVUAC012E	1/2"	15	16	125	72	55	149	22,5	104	231
RVUAC034E	3/4"	20	16	145	84	66	172	25,5	121	392
RVUAC100E	1"	25	16	165	95	75	190	28,7	132,6	576
RVUAC114E	1" 1/4	32	10	190	111	87	223	32	159	802
RVUAC112E	1" 1/2	40	10	210	120	100	251	35	181	1199
RVUAC200E	2"	50	10	240	139	120	298	38,2	221,6	2018

FKM

Reference	d	DN	PN	A max	B	E	H	L	Z	g
RVUAC012F	1/2"	15	16	125	72	55	149	22,5	104	231
RVUAC034F	3/4"	20	16	145	84	66	172	25,5	121	392
RVUAC100F	1"	25	16	165	95	75	190	28,7	132,6	576

All information subject to change.

Please contact us on <https://www.aliaxis.co.uk/get-in-touch> for further informations



RVUAC - Sediment strainer DN 15:50

Reference	d	DN	PN	A max	B	E	H	L	Z	g
RVUAC114F	1" 1/4	32	10	190	111	87	223	32	159	802
RVUAC112F	1" 1/2	40	10	210	120	100	251	35	181	1199
RVUAC200F	2"	50	10	240	139	120	298	38,2	221,6	2018

All information subject to change.

Please contact us on <https://www.aliaxis.co.uk/get-in-touch> for further informations

