

RVUOC - Sediment strainer DN 15:50

Sediment strainer with fixed flanges, drilled EN/ISO/DIN PN10/16.

The RV sediment strainer limits the passage of any solid particles present in the fluid by means of a strainer.

- Connection system for solvent weld, threaded and flanged joints
- **Strainer** mounted on an easily removed **support** that facilitates the cleaning or replacement
- **Valve material compatibility** (PVC-C) with water conveyance, drinking water and other food substances according to **current regulations**
- Can be maintained with the valve body installed

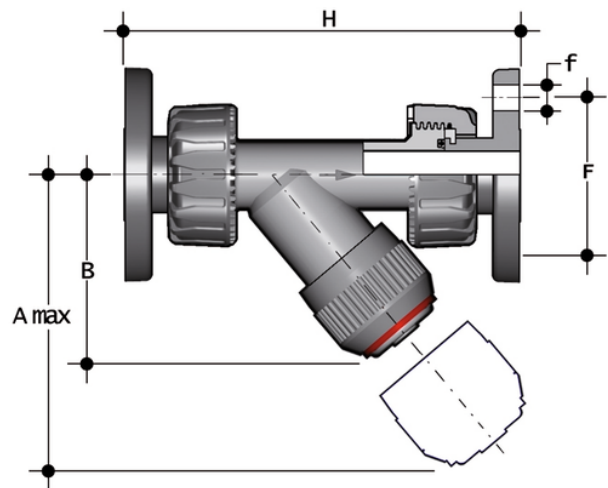

EPDM

Reference	d	DN	PN	A max	B	F	f	H	g
RVUOC020E	20	15	16	125	72	65	14	163	360
RVUOC025E	25	20	16	145	84	75	14	193	495
RVUOC032E	32	25	16	165	95	85	14	211	660
RVUOC040E	40	32	16	190	111	100	18	244	1000
RVUOC050E	50	40	16	210	120	110	18	277	1320
RVUOC063E	63	50	16	240	139	125	18	331	1910

FKM

Reference	d	DN	PN	A max	B	F	f	H	g
RVUOC020F	20	15	16	125	72	65	14	163	360
RVUOC025F	25	20	16	145	84	75	14	193	495
RVUOC032F	32	25	16	165	95	85	14	211	660

All information subject to change.

Please contact us on <https://www.aliaxis.co.uk/get-in-touch> for further informations



RVUOC - Sediment strainer DN 15:50

Reference	d	DN	PN	A max	B	F	f	H	g
RVUOC040F	40	32	16	190	111	100	18	244	1000
RVUOC050F	50	40	16	210	120	110	18	277	1320
RVUOC063F	63	50	16	240	139	125	18	331	1910

All information subject to change.

Please contact us on <https://www.aliaxis.co.uk/get-in-touch> for further informations

