

# VRDV – Check valve DN 10:100

Check valve with male ends for solvent welding, metric series.

The VR is an angle seat check valve with weighted PVC piston that allows the passage of fluid in one direction only.

- Connection system for solvent weld, threaded and flanged joints
- **No metal parts in contact with the fluid**
- **Piston with counterweight** able to work with high intensity fluid
- Limited pressure drop. Only minimum back pressure is required for the hermetic seal
- **Valve material compatibility** (PVC-U) with water conveyance, drinking water and other food substances according to **current regulations**
- Can be maintained with the valve body installed

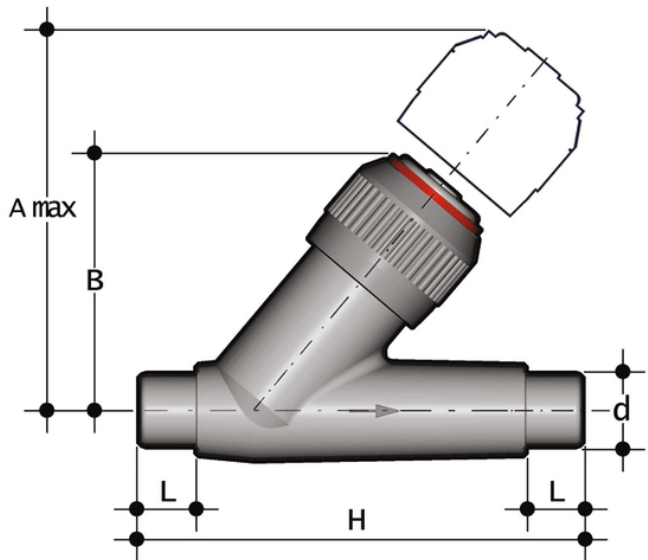

| Reference | d  | DN | PN | A max | B   | H   | L  | Fig. | g    |
|-----------|----|----|----|-------|-----|-----|----|------|------|
| VRDV016E  | 16 | 10 | 16 | 125   | 72  | 114 | 14 | A    | 125  |
| VRDV020E  | 20 | 15 | 16 | 125   | 72  | 124 | 16 | A    | 135  |
| VRDV025E  | 25 | 20 | 16 | 145   | 84  | 144 | 19 | A    | 225  |
| VRDV032E  | 32 | 25 | 16 | 165   | 95  | 154 | 22 | A    | 360  |
| VRDV040E  | 40 | 32 | 16 | 190   | 111 | 174 | 26 | A    | 590  |
| VRDV050E  | 50 | 40 | 16 | 210   | 120 | 194 | 31 | A    | 835  |
| VRDV063E  | 63 | 50 | 16 | 240   | 139 | 224 | 38 | A    | 1420 |

All information subject to change.

Please contact us on <https://www.aliasis.co.uk/get-in-touch> for further informations