

# VROV D 20 ÷ 63 - Check valve DN 10:100

Check valve with fixed flanges, drilled PN10/16.

The VR is an angle seat check valve with weighted PVC piston that allows the passage of fluid in one direction only.

- Connection system for solvent weld, threaded and flanged joints
- **No metal parts in contact with the fluid**
- **Piston with counterweight** able to work with high intensity fluid
- Limited pressure drop. Only minimum back pressure is required for the hermetic seal
- **Valve material compatibility** (PVC-U) with water conveyance, drinking water and other food substances according to **current regulations**
- Can be maintained with the valve body installed

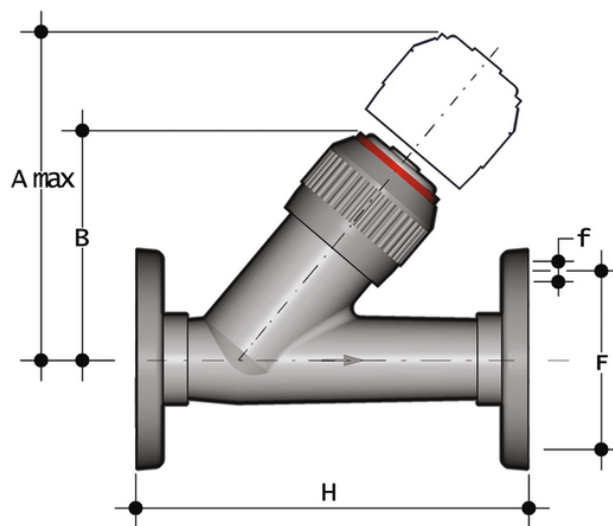

## EPDM

Reference	d	DN	PN	A max	B	F	f	H	Fig.	g
VROV020E	20	15	16	125	72	65	14	130	A	280
VROV025E	25	20	16	145	84	75	14	150	A	430
VROV032E	32	25	16	165	95	85	14	160	A	640
VROV040E	40	32	16	190	111	100	18	180	A	1035
VROV050E	50	40	16	210	120	110	18	200	A	1405
VROV063E	63	50	16	240	139	125	18	230	A	2235

## FKM

Reference	d	DN	PN	A max	B	F	f	H	Fig.	g
VROV020F	20	15	16	125	72	65	14	130	A	280

All information subject to change.

Please contact us on <https://www.aliaxis.co.uk/get-in-touch> for further informations



# VROV D 20 ÷ 63 - Check valve DN 10:100

Reference	d	DN	PN	A max	B	F	f	H	Fig.	g
VROV025F	25	20	16	145	84	75	14	150	A	430
VROV032F	32	25	16	165	95	85	14	160	A	640
VROV040F	40	32	16	190	111	100	18	180	A	1035
VROV050F	50	40	16	210	120	110	18	200	A	1405
VROV063F	63	50	16	240	139	125	18	230	A	2235

All information subject to change.

Please contact us on <https://www.aliasis.co.uk/get-in-touch> for further informations

