

RVUAT - Sediment strainer DN 10:100

PVC-U transparent.

Sediment strainer with female union ends for solvent welding, series ASTM.

The RV Sediment strainer limits the passage of any solid particles present in the fluid by means of a strainer.

- Connection system for solvent weld, threaded and flanged joints
- **Strainer** mounted on an easily removed **support** that facilitates the cleaning or replacement
- **Valve material compatibility** (PVC-U) with water conveyance, drinking water and other food substances according to **current regulations**
- Can be maintained with the valve body installed

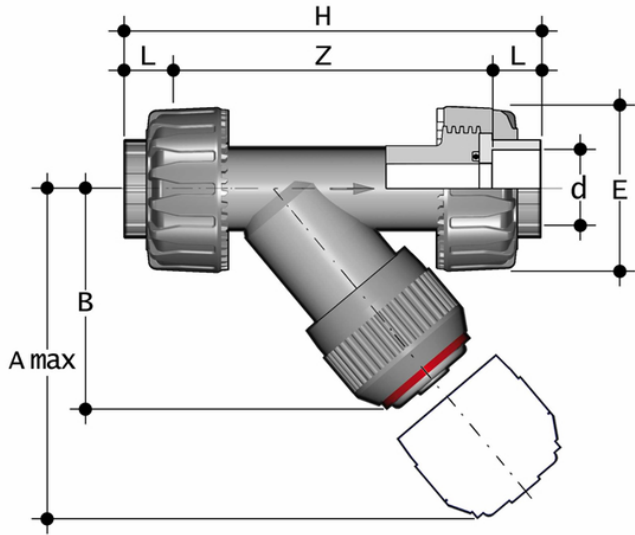

Reference	d	DN	PN	A max	B	E	H	L	Z	Fig.	g
RVUAT038E	3/8"	10	16	125	72	55	149	19,5	110	A	203
RVUAT012E	1/2"	15	16	125	72	55	149	22,5	104	A	211
RVUAT034E	3/4"	20	16	145	84	66	172	25,5	121	A	358
RVUAT100E	1"	25	16	165	95	75	190	28,7	132,6	A	526
RVUAT114E	1" 1/4	32	10	190	111	87	223	32	159	A	733
RVUAT112E	1" 1/2	40	10	210	120	100	251	35	181	A	1095
RVUAT200E	2"	50	10	240	139	120	298	38,2	221,6	A	1843

All information subject to change.

Please contact us on <https://www.aliaxis.co.uk/get-in-touch> for further informations