

RVOV-RVOT D 75 ÷ 110 - Sediment strainer DN 10:100

RVOV PVC-U rigid - RVOT PVC-U transparent.
Sediment strainer with PVC-U backing ring, drilled PN10/16.

The RV Sediment strainer limits the passage of any solid particles present in the fluid by means of a strainer.

- Connection system for solvent weld, threaded and flanged joints
- **Strainer** mounted on an easily removed **support** that facilitates the cleaning or replacement
- **Valve material compatibility** (PVC-U) with water conveyance, drinking water and other food substances according to **current regulations**
- Can be maintained with the valve body installed

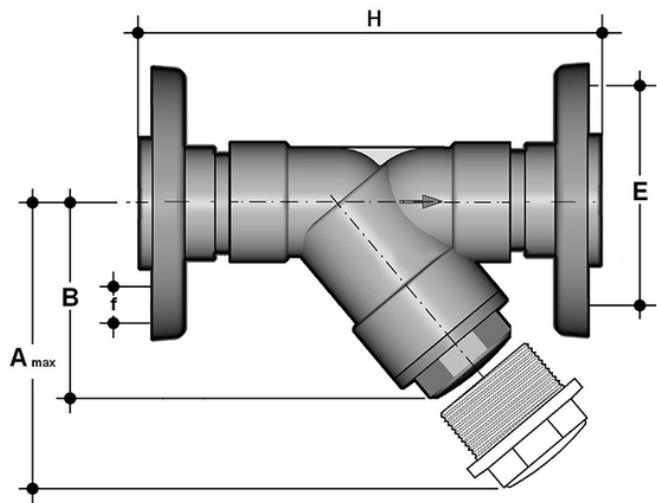

EPDM

Reference	d	DN	PN RVOV	PN RVOT	A max	B	F	f	H	Fig.	g
RVOV075E	75	65	10	6	300	179	145	17	356	B	3600
RVOV090E	90	80	6	4	325	192	160	17	404	B	4910
RVOV110E	110	100	6	4	385	231	180	17	475	C	6790
RVOT075E	75	65	10	6	300	179	145	17	356	B	3600
RVOT090E	90	80	6	4	325	192	160	17	404	B	4910
RVOT110E	110	100	6	4	385	231	180	17	475	C	6790

All information subject to change.

Please contact us on <https://www.aliasis.co.uk/get-in-touch> for further informations