

RVOAV-RVOAT D 20 ÷ 63 - Sediment strainer PN 10:100

RVOAV PVC-U rigid - RVOAT PVC-U transparent.
Sediment strainer with fixed flanges, drilled ANSI B16.5 cl.150 #FF.

The RV Sediment strainer limits the passage of any solid particles present in the fluid by means of a strainer.

- Connection system for solvent weld, threaded and flanged joints
- **Strainer** mounted on an easily removed **support** that facilitates the cleaning or replacement
- **Valve material compatibility** (PVC-U) with water conveyance, drinking water and other food substances according to **current regulations**
- Can be maintained with the valve body installed

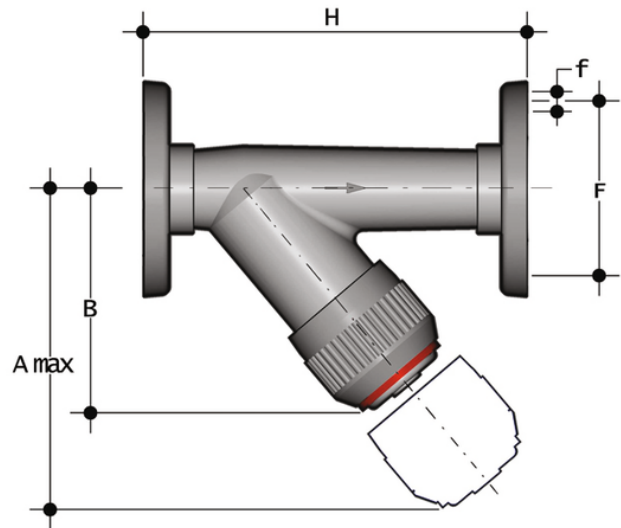

EPDM

Reference	d	DN	PN RVOAV	PN RVOAT	A max	B	F	f	H	Fig.	g
RVOAV012E	1/2"	15	16	10	125	72	60,3	15,9	130	A	260
RVOAT112E	1 1/2"	40	16	10	210	120	98,4	15,9	200	A	1170
RVOAT114E	1 1/4"	32	16	10	190	111	88,9	15,9	180	A	850
RVOAT100E	1"	25	16	10	165	95	79,4	15,9	160	A	560
RVOAT034E	3/4"	20	16	10	145	84	69,9	15,9	150	A	395
RVOAT012E	1/2"	15	16	10	125	72	60,3	15,9	130	A	260
RVOAV200E	2"	50	16	10	240	139	120,7	19,1	230	A	1760
RVOAV112E	1 1/2"	40	16	10	210	120	98,4	15,9	200	A	1170
RVOAV114E	1 1/4"	32	16	10	190	111	88,9	15,9	180	A	850
RVOAV100E	1"	25	16	10	165	95	79,4	15,9	160	A	560
RVOAV034E	3/4"	20	16	10	145	84	69,9	15,9	150	A	395

All information subject to change.

Please contact us on <https://www.aliasis.co.uk/get-in-touch> for further informations



RVOAV-RVOAT D 20 ÷ 63 - Sediment strainer PN 10:100

Reference	d	DN	PN RVOAV	PN RVOAT	A max	B	F	f	H	Fig.	g
RVOAT200E	2"	50	16	10	240	139	120,7	19,1	230	A	1760

All information subject to change.

Please contact us on <https://www.aliasis.co.uk/get-in-touch> for further informations

