

RVOAV-RVOAT D 75 ÷ 110 - Sediment strainer DN 10:100

RVOAV PVC-U rigid - RVOAT PVC-U transparent.

Sediment strainer with steel core backing ring , PP/FRP coated, drilled ANSI B16.5 cl.150 #FF.

The RV Sediment strainer limits the passage of any solid particles present in the fluid by means of a strainer.

- Connection system for solvent weld, threaded and flanged joints
- **Strainer** mounted on an easily removed **support** that facilitates the cleaning or replacement
- **Valve material compatibility** (PVC-U) with water conveyance, drinking water and other food substances according to **current regulations**
- Can be maintained with the valve body installed

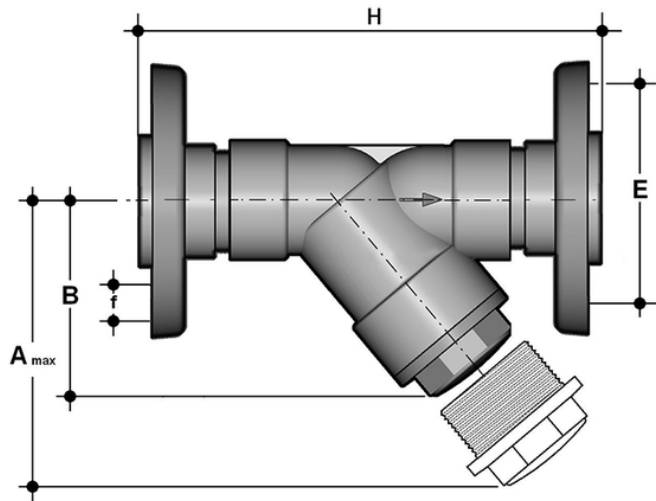

EPDM

Reference	d	DN	PN RVOAV	PN RVOAT	A max	B	F	f	H	Fig.	g
RVOAV212E	2"1/2	65	10	6	300	179	139,7	19,1	356	B	3600
RVOAV300E	3"	80	6	4	325	192	152,4	19,1	404	B	4910
RVOAV400E	4"	100	6	4	385	231	190,5	19,1	475	C	6790
RVOAT212E	2"1/2	65	10	6	300	179	139,7	19,1	356	B	3600
RVOAT300E	3"	80	6	4	325	192	152,4	19,1	404	B	4910
RVOAT400E	4"	100	6	4	385	231	190,5	19,1	475	C	6790

All information subject to change.

Please contact us on <https://www.aliasis.co.uk/get-in-touch> for further informations