

VKRIM/CE 90-240 V AC 4-20 mA - Electrically actuated DUAL BLOCK® regulating ball valve DN 10:50

Electrically actuated DUAL BLOCK® regulating ball valve with metric plain socket ends for socket welding and modulating electric actuator multivolt 90-240 V AC 50-60 Hz.

The VKR DUAL BLOCK® valve combines high reliability and safety aspects typical of VKD full bore ball valves with the new flow adjustment function with typical linear curve that meets the most stringent needs typical of industrial applications.

In addition to the manually actuated version, VKR is also available in electrically actuated VKR/CE configuration. Actuators are firmly connected to the valve by the special FIP PowerQuick modules fully made of PP-GR technopolymer. VKR/CE are constructed with actuators meeting current regulations and selected by FIP according to their quality and reliability requirements. The efficiency of these valves, tested according to the company's quality standards, is guaranteed by the expertise and know-how that FIP dedicates to manufacturing its products.

- Electric modulating actuator constructed according to FIP specifications; with plastic shell and standard emergency override. Available with voltages from 12 to 240V with 4-20mA and 0-10 V input
- High surface finish stem with double O-Ring. The double connection key system guarantees solid and reliable actuator torque transmission to the ball
- Easy to install PowerQuick module for pneumatic or electric actuator fully made of highly robust technopolymer
- The patented ball design provides linear flow regulation throughout its range of operation even when the valve is open just a few degrees and guarantees minimum pressure drops
- Patented DUAL BLOCK® system: prevents union nuts from loosening even under extreme operating conditions: e.g. vibration or thermal expansion
- Joint system for solvent welding (PVC-U only), for welding (PP-H and PVDF only), for threading and flanging
- Patented SEAT STOP® ball carrier system that lets you micro-adjust ball seats and minimise the axial force effect.
- Easy radial disassembly allowing quick replacement of O-rings and ball seats without any need for tools
- Radial dismounting valve body (True Union) made for PVC-U, PVC-C and PVDF-H injection moulding equipped with built-in bores for actuation. ISO 9393 compliant test requisites
- Option of disassembling downstream pipes with the valve in the closed position
- High surface finish stem with double O-Ring and double groove ball connection
- Integrated bracket for valve anchoring
- Ball seat carrier can be adjusted using the Easytorque adjustment kit
- Actuation option: version with electric modulating actuator with 4-20 mA / 0-10 V inlet and 4-20 mA / 0-10 V outlet to monitor the position
- Valve suitable for carrying fluids that are clean and free of suspended particles

All information subject to change.

Please contact us on <https://www.aliaxis.co.uk/get-in-touch> for further informations

VKRIM/CE 90-240 V AC 4-20 mA - Electrically actuated DUAL BLOCK® regulating ball valve DN 10:50

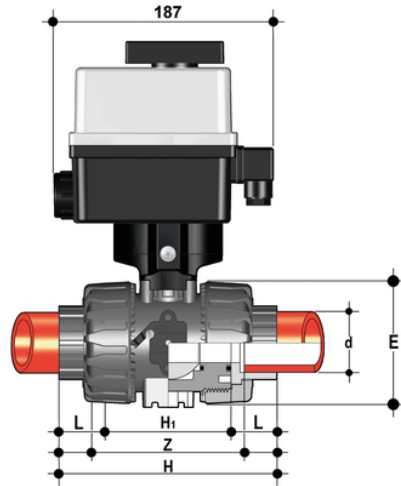

EPDM

Reference	d	DN	B	B ₁	PN	E	H	H ₁	L	Z	g
VKRIMEM016EOE	16	10	205	29	10	54	102	65	14	74.5	1720
VKRIMEM020EOE	20	15	205	29	10	54	102	65	15	73	1715
VKRIMEM025EOE	25	20	216	34.5	10	65	114	70	17	82	1791
VKRIMEM032EOE	32	25	221	39	10	73	126	78	19	90	1871
VKRIMEM040EOE	40	32	238	46	10	86	141	88	23	100	2156
VKRIMEM050EOE	50	40	244	52	10	98	164	93	24	117	2358
VKRIMEM063EOE	63	50	261	62	10	122	199	111	28	144	2807

FKM

Reference	d	DN	B	B ₁	PN	E	H	H ₁	L	Z	g
VKRIMEM016FOE	16	10	205	29	10	54	102	65	14	74.5	1720
VKRIMEM020FOE	20	15	205	29	10	54	102	65	15	73	1715
VKRIMEM025FOE	25	20	216	34.5	10	65	114	70	17	82	1791
VKRIMEM032FOE	32	25	221	39	10	73	126	78	19	90	1871
VKRIMEM040FOE	40	32	238	46	10	86	141	88	23	100	2156
VKRIMEM050FOE	50	40	244	52	10	98	164	93	24	117	2358
VKRIMEM063FOE	63	50	261	62	10	122	199	111	28	144	2807

All information subject to change.

Please contact us on <https://www.aliaxis.co.uk/get-in-touch> for further informations