

# LKDDM/CP SA – Pneumatically actuated DUAL BLOCK® 3-way ball valve DN 10:50

3 way DUAL BLOCK® ball valve with male ends for socket welding with pneumatic actuator, Single-acting function. "L" ball.

FIP has developed a TKD DUAL BLOCK® ball valve to introduce a high reference standard in thermoplastic valve design. TKD is a True Union diverting and mixing ball valve that meets the most stringent needs required in industrial applications.

In addition to the manually actuated version, TKD is also available in TKD/CE electrically actuated and TKD/CP pneumatically actuated configurations. Actuators are firmly connected to the valve by the special FIP PowerQuick modules fully made of PP-GR technopolymer. TKD/CE and TKD/CP are constructed with actuators meeting current regulations and selected by FIP according to their quality and reliability requirements. The efficiency of these valves, tested according to the company's quality standards, is guaranteed by the expertise and know-how that FIP dedicates to manufacturing its products.

- Electric actuator constructed according to FIP specifications; with plastic shell and standard emergency override. Available with voltages from 12 to 240V
- Rack & pinion type pneumatic actuator constructed according to FIP specifications: fully protected against weather corrosion available in double-acting (DA) or simple-acting normally closed (NC) or normally open (NO) versions. Three different positions according to 2 configurations are possible with T ball: 0°-90°-180° and 0°-90°-270°
- High surface finish stem with double O-Ring. The double connection key system guarantees solid and reliable actuator torque transmission to the ball
- Easy to install PowerQuick module for pneumatic or electric actuator fully made of highly robust technopolymer
- DUAL BLOCK® patented lock system that ensures union nut tightening hold even in severe conditions such as vibrations or heat dilation
- Ball shutter high surface finish with floating type full passage with T or L port
- Joint system for solvent welding (PVC-U and PVC-C only), for welding (PP-H only), for threading
- Patented SEAT STOP® ball seat carrier system that lets you micro-adjust ball seats and minimise axial force effects
- Easy radial disassembly allowing quick replacement of O-rings and ball seats without any need for tools
- Radial dismounting valve body (True Union) made for PVC-U, PVC-C and PP-H injection moulding equipped with built-in bores for actuation. ISO 9393 compliant test requisites
- Option of disassembling downstream pipes with the valve in the closed position
- High surface finish stem with double O-Ring and double connection key to the ball, equipped with visual ball position indicator for correct handle installation
- Integrated bracket for valve anchoring
- Possibility of installing pneumatic and/or electric actuators thanks to the robust anchor tower for easy and quick automation using the PowerQuick module

All information subject to change.

Please contact us on <https://www.aliaxis.co.uk/get-in-touch> for further informations

# LKDDM/CP SA - Pneumatically actuated DUAL BLOCK® 3-way ball valve DN 10:50

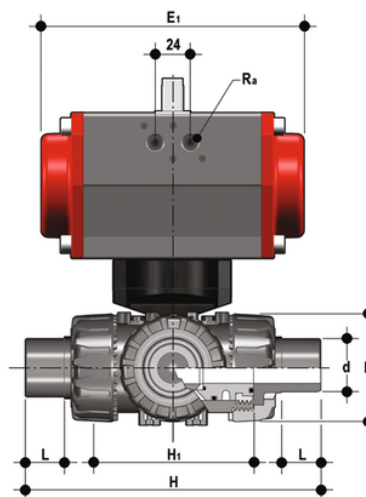
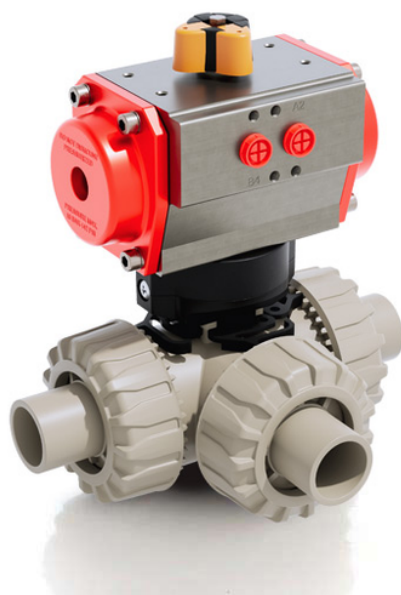

## EPDM

Reference	d	DN	PN	E	H	H1	L	R <sub>a</sub>	B	B <sub>1</sub>	E <sub>1</sub>	E <sub>2</sub>	g
LKDDMSA020E1	20	15	10	54	140	80	16	G1/8"	145	29	138	86	2172
LKDDMSA025E1	25	20	10	65	175	100	18	G1/8"	156.5	34.5	155.5	86	2436
LKDDMSA032E1	32	25	10	73	188	110	20	G1/8"	161	39	155.5	86	2732
LKDDMSA040E1	40	32	10	86	220	131	22	G1/4"	194	46	155.5	86	3225
LKDDMSA050E1	50	40	10	98	251	148	23	G1/4"	200	52	155.5	86	3610
LKDDMSA063E1	63	50	10	122	294	179	29	G1/4"	217	62	210	94	6414

## FKM

Reference	d	DN	PN	E	H	H1	L	R <sub>a</sub>	B	B <sub>1</sub>	E <sub>1</sub>	E <sub>2</sub>	g
LKDDMSA020F1	20	15	10	54	140	80	16	G1/8"	145	29	138	86	2172
LKDDMSA025F1	25	20	10	65	175	100	18	G1/8"	156.5	34.5	155.5	86	2436
LKDDMSA032F1	32	25	10	73	188	110	20	G1/8"	161	39	155.5	86	2732
LKDDMSA040F1	40	32	10	86	220	131	22	G1/4"	194	46	155.5	86	3225
LKDDMSA050F1	50	40	10	98	251	148	23	G1/4"	200	52	155.5	86	3610
LKDDMSA063F1	63	50	10	122	294	179	29	G1/4"	217	62	210	94	6414

All information subject to change.

Please contact us on <https://www.aliaxis.co.uk/get-in-touch> for further informations