

# VXE/BEV/CE 24 V AC/DC - electrically actuated EASYFIT 2- way ball valve

2-way Easyfit valve with PE100 SDR 11 male ends for butt welding or electrofusion welding (CVDE) with electric actuator 24V AC/DC.

FIP and Giugiaro Design designed and developed VXE Easyfit, the innovative True Union ball valve with union nut tightening control system that permits simple and safe installation for reliable service in time.

In addition to the manually actuated version, VXE is also available in VXE/CE electrically actuated and VXE/CP pneumatically actuated configurations. Actuators are firmly connected to the valve by the special FIP Power Quick modules fully made of PP-GR technopolymer. VXE/CE and VXE/CP are constructed with actuators meeting current regulations and selected by FIP according to their quality and reliability requirements. The efficiency of these valves, tested according to the company's quality standards, is guaranteed by the expertise and know-how that FIP dedicates to manufacturing its products.

- Electric actuator constructed according to FIP specifications; with plastic shell and standard emergency override. Available with voltages from 12 to 240V
- Rack & pinion type pneumatic actuator constructed according to FIP specifications: fully protected against weather corrosion available in double-acting (DA) or simple-acting normally closed (NC) or normally open (NO) versions
- Stem with high surface finish and double O-Ring and PTFE antifriction disk that limits friction to a minimum and grants excellent operating torque
- Easy to install Easyfit PowerQuick module for pneumatic or electric actuator fully made of highly robust technopolymer
- Connection system using solvent welded and threaded joints
- Patented Easyfit system: innovative mechanism based on the multifunctional handle quick release mechanism that permits union nut rotation during valve installation and ball seat carrier adjustment
- Valve material compatibility (U PVC-C) and elastomer seal elements (EPDM or FKM), with water, drinking water and other food substances as per current regulations
- Easy radial dismounting allowing quick replacement of O-rings and ball seats without any need for tools
- PN16 radial dismounting valve body (True Union) made for PVC-C injection moulding and European Directive 2014/68/EC compliant for PED pressurised equipment. ISO 9393 compliant test requirements. Maximum fluid pressure for valve operation 6 bar.
- Valve body with built in anchoring frame for the special Power Quick module dedicated to accessory or pneumatic and electric actuator installation
- Option of disassembling downstream pipes with the valve in the closed position
- Floating full bore ball with high surface finish made in CNC work stations to achieve precise dimensional tolerance and high surface finish

All information subject to change.

Please contact us on <https://www.aliaxis.co.uk/get-in-touch> for further informations

# VXEBEV/CE 24 V AC/DC - electrically actuated EASYFIT 2- way ball valve

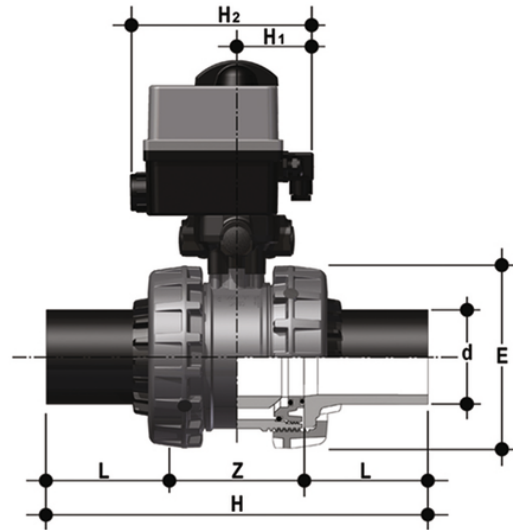

## EPDM

Reference	d	DN	*PN	E	H	L	Z	B	H1	H2	E <sub>1</sub>	g
VXEBEVEL075E	75	65	6	157	331	71	189	276	82	187	92	3286
VXEBEVEL090E	90	80	6	174	367	88	191	312	93	188	128	5159
VXEBEVEL110E	110	100	6	212	407	92	223	332	93	188	128	7573

## FKM

Reference	d	DN	*PN	E	H	L	Z	B	H1	H2	E <sub>1</sub>	g
VXEBEVEL075F	75	65	6	157	331	71	189	276	82	187	92	3286
VXEBEVEL090F	90	80	6	174	367	88	191	312	93	188	128	5159
VXEBEVEL110F	110	100	6	212	407	92	223	332	93	188	128	7573

All information subject to change.

Please contact us on <https://www.aliasis.co.uk/get-in-touch> for further informations