

DKUIM/CP NC – Pneumatically actuated 2-way diaphragm valve

PN 10 DN 15:65

Pneumatically actuated diaphragm valve with female union ends for socket fusion, metric series. Normally Closed function.

The DK diaphragm valve is particularly suitable for shutting off and regulating abrasive or dirty fluids. The new internal geometry of the body significantly increases the flow coefficient, reduces pressure drops and allows accurate adjustment over the entire shutter stroke. The DK is extremely compact and very light. The innovative handwheel is equipped with a patented immediate and ergonomic locking device that allows it to be adjusted and locked in any position.

The new compact and light piston actuator in PP-GR makes the DK/CP the ideal choice for applications requiring very frequent valve operation and a long valve lifetime.

- High visibility graduated optical position indicator protected by a transparent cap with a seal O-Ring.
- Compact and light piston in PP-GR, ideal for heavy-duty applications in chemically aggressive environments with a diaphragm perimeter containment system that ensures the perfect compression of the rubber without any lateral expansion.
- Piston in high strength IXEF[®]. The high quality finishing of the external surface guarantees perfect slidability over the seal and ensures a long working life without any actuator maintenance.
- High strength stainless steel stem with double seal O-Ring. Floating pin connection between the actuator stem and diaphragm to prevent concentrated loads, improve the seal and extend its lifetime.
- Actuator equipped with 6 independent cartridge springs arranged radially to uniformly distribute the load on the piston.
- Dual function main gasket. Piston seal: the gasket does not move but sits securely on the actuator cylinder instead of the piston. External seal: the gasket positioned above the threaded joint between the bonnet and cylinder ensures that the coupling is not stressed by the pressure inside the actuator.
- Easy installation in confined spaces: compressed air inlets with G 1/4" threaded adjustable connections to enable alignment with the piping. PPGR connections prevent any risk of corrosion.
- New valve body internal design. Substantially higher flow coefficient and lower pressure drops. The degree of efficiency reached has also enabled the size and weight of the valve to be reduced. Adjustment linearity: the internal profiles of the valve greatly improve its characteristic curve, allowing extremely sensitive and precise adjustment along the entire length of the shutter stroke.
- Joint system for solvent welding (PVC-U and PVC-C only), for welding (PP-H and PVDF only), for threading and flanging
- Optimised fluid dynamic design: maximum output flow rate thanks to the optimised efficiency of the fluid dynamics that characterise the new internal geometry of the body
- Internal operating components in metal totally isolated from the conveyed fluid and external environment
- Modularity of the range: only 2 hand wheels and 4 diaphragms and bonnet sizes for 7 different valve sizes
- Non-salient hand wheel, equipped with a graduated optical indicator and protected by a transparent PVC cap with sealing O-ring.
- Bonnet fastening screws in STAINLESS steel protected by PE plugs. Absence of metal parts exposed to the external environment to prevent any risk of corrosion
- New flanged bodies: the new bodies, characterised by a monolithic flanged structure, are available in PVC-U, PVC-C, PP-H and PVDF. This design, free of joints between the body and flanges, greatly reduces mechanical stress and increases system performance
- CDSA seal system (Circular Diaphragm Sealing Angle) with a uniform distribution of the shutter pressure on the sealing membrane offers the following advantages:
 - Operating torque reduction
 - Reduced mechanical stress on all valve components (actuator, body and diaphragm)
 - Low risk of the accumulation of deposits, contamination or damage to the diaphragm due to crystallisation
 - Easy to clean valve interior

All information subject to change.

Please contact us on <https://www.aliaxis.co.uk/get-in-touch> for further informations

DKUIM/CP NC – Pneumatically actuated 2-way diaphragm valve PN 10 DN 15:65

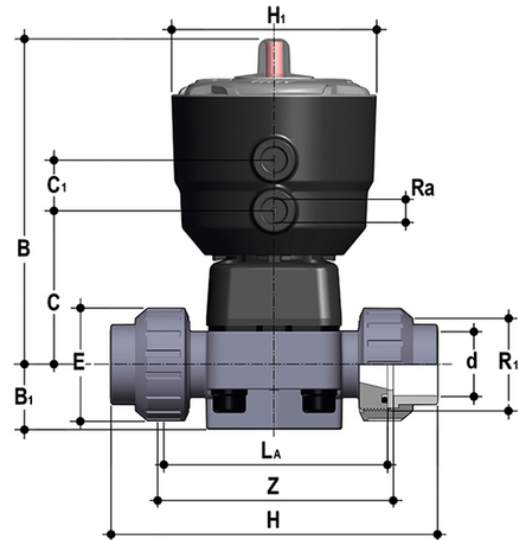

EPDM

Reference	d	DN	PN	B	B ₁	C	C ₁	E	H	H ₁	L[5:α]	R ₁	R[5:α]	Z	g
DKUIMNC020E	20	15	10	148	25	66	24	41	129	97	90	1"	1/4"	100	689
DKUIMNC025E	25	20	10	151	30	69	24	50	154	97	108	1 1/4"	1/4"	116	735
DKUIMNC032E	32	25	10	159	33	78	24	58	168	97	116	1 1/2"	1/4"	124	930
DKUIMNC040E	40	32	10	163	30	82	24	72	192	97	134	2"	1/4"	140	1016
DKUIMNC050E	50	40	10	207	35	112	24	79	222	126	154	2 1/4"	1/4"	160	2711
DKUIMNC063E	63	50	10	245	46	142	24	98	266	157	184	2 3/4"	1/4"	190	5929

FKM

Reference	d	DN	PN	B	B ₁	C	C ₁	E	H	H ₁	L[5:α]	R ₁	R[5:α]	Z	g
DKUIMNC020F	20	15	10	148	25	66	24	41	129	97	90	1"	1/4"	100	689
DKUIMNC025F	25	20	10	151	30	69	24	50	154	97	108	1 1/4"	1/4"	116	735
DKUIMNC032F	32	25	10	159	33	78	24	58	168	97	116	1 1/2"	1/4"	124	930
DKUIMNC040F	40	32	10	163	30	82	24	72	192	97	134	2"	1/4"	140	1016
DKUIMNC050F	50	40	10	207	35	112	24	79	222	126	154	2 1/4"	1/4"	160	2711
DKUIMNC063F	63	50	10	245	46	142	24	98	266	157	184	2 3/4"	1/4"	190	5929

PTFE

All information subject to change.

Please contact us on <https://www.aliasis.co.uk/get-in-touch> for further informations

DKUIM/CP NC – Pneumatically actuated 2-way diaphragm valve

PN 10 DN 15:65

Reference	d	DN	PN	B	B ₁	C	C ₁	E	H	H ₁	L[5:α]	R ₁	R[5:α]	Z	g
DKUIMNC020P	20	15	10	148	25	66	24	41	129	97	90	1"	1/4"	100	689
DKUIMNC025P	25	20	10	151	30	69	24	50	154	97	108	1"1/4	1/4"	116	735
DKUIMNC032P	32	25	10	159	33	78	24	58	168	97	116	1"1/2	1/4"	124	930
DKUIMNC040P	40	32	10	163	30	82	24	72	192	97	134	2"	1/4"	140	1016
DKUIMNC050P	50	40	10	207	35	112	24	79	222	126	154	2"1/4	1/4"	160	2711
DKUIMNC063P	63	50	10	245	46	142	24	98	266	157	184	2"3/4	1/4"	190	5929

All information subject to change.

Please contact us on <https://www.aliasis.co.uk/get-in-touch> for further informations