

DKULV/CP NC – Pneumatically actuated 2-way diaphragm valve

PN 10 DN 15:65

Pneumatically actuated diaphragm valve with female union ends for solvent welding, BS series. Normally Closed function.

The DK diaphragm valve is particularly suitable for shutting off and regulating abrasive or dirty fluids. The new internal geometry of the body significantly increases the flow coefficient, reduces pressure drops and allows accurate adjustment over the entire shutter stroke. The DK is extremely compact and very light. The innovative handwheel is equipped with a patented immediate and ergonomic locking device that allows it to be adjusted and locked in any position.

The new compact and light piston actuator in PP-GR makes the DK/CP the ideal choice for applications requiring very frequent valve operation and a long valve lifetime.

- **High visibility graduated optical position indicator** protected by a transparent cap with a seal O-Ring
- **Compact and light piston in PP-GR**, ideal for heavy-duty applications in chemically aggressive environments with a **diaphragm perimeter containment system** that ensures the perfect compression of the rubber without any lateral expansion
- **Piston in high strength IXEF®**. The high quality finishing of the external surface guarantees perfect slidability over the seal and ensures a long working life without any actuator maintenance
- High strength **stainless steel stem** with double seal O-Ring. Floating **pin connection** between the actuator stem and diaphragm to prevent concentrated loads, improve the seal and extend its lifetime
- Actuator equipped with **6 independent cartridge springs** arranged radially to uniformly distribute the load on the piston
- **Dual function main gasket. Piston seal:** the gasket does not move but sits securely on the actuator cylinder instead of the piston. **External seal:** the gasket positioned above the threaded joint between the bonnet and cylinder ensures that the coupling is not stressed by the pressure inside the actuator
- Easy installation in confined spaces: **compressed air inlets with G 1/4" threaded adjustable connections** to enable alignment with the piping. PPGR connections prevent any risk of corrosion
- **New valve body internal design. Substantially higher flow coefficient** and lower pressure drops. The degree of efficiency reached has also enabled the **size and weight of the valve to be reduced. Adjustment linearity:** the internal profiles of the valve greatly improve its characteristic curve, allowing **extremely sensitive and precise adjustment** along the entire length of the shutter stroke
- Joint system for solvent welding (PVC-U and PVC-C only), for welding (PP-H and PVDF only), for threading and flanging
- **Optimised fluid dynamic design:** maximum output flow rate thanks to the optimised efficiency of the fluid dynamics that characterise the new internal geometry of the body
- **Internal operating components in metal totally isolated from the conveyed fluid** and external environment
- **Modularity of the range:** only 2 hand wheels and 4 diaphragms and bonnet sizes for 7 different valve sizes
- Non-salient hand wheel, equipped with a graduated optical indicator and protected by a transparent PVC cap with sealing O-ring
- Bonnet fastening screws in STAINLESS steel protected by PE plugs. Absence of metal parts exposed to the external environment to prevent any risk of corrosion
- **New flanged bodies:** the new bodies, characterised by a monolithic flanged structure, are available in PVC-U, PVC-C, PP-H and PVDF. This design, free of joints between the body and flanges, greatly reduces mechanical stress and increases system performance
- **CDSA seal system** (Circular Diaphragm Sealing Angle) with a uniform distribution of the shutter pressure on the sealing membrane offers the following advantages:
 - Operating torque reduction
 - Reduced mechanical stress on all valve components (actuator, body and diaphragm)
 - Low risk of the accumulation of deposits, contamination or damage to the diaphragm due to crystallisation
 - Easy to clean valve interior

All information subject to change.

Please contact us on <https://www.aliaxis.co.uk/get-in-touch> for further informations

DKULV/CP NC – Pneumatically actuated 2-way diaphragm valve PN 10 DN 15:65

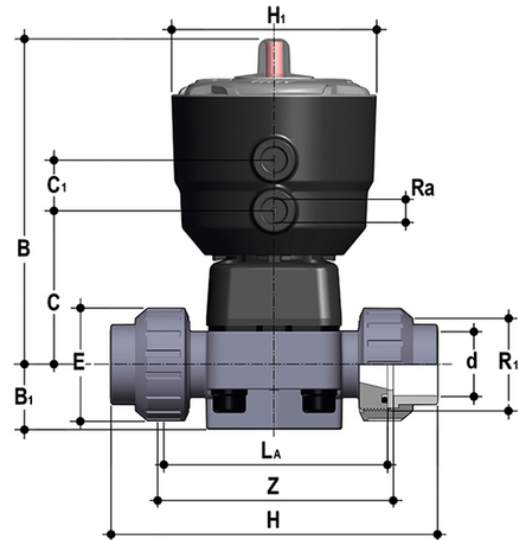

EPDM

| Reference | d | DN | PN | B | B ₁ | C | C ₁ | E | H | H ₁ | L[5:α] | R ₁ | R[5:α] | Z | g |
|-------------|--------|----|----|-----|----------------|-----|----------------|----|-----|----------------|--------|----------------|--------|-----|------|
| DKULVNC012E | 1/2" | 15 | 10 | 148 | 25 | 66 | 24 | 41 | 131 | 97 | 90 | 1" | 1/4" | 97 | 735 |
| DKULVNC034E | 3/4" | 20 | 10 | 151 | 30 | 69 | 24 | 50 | 154 | 97 | 108 | 1 1/4" | 1/4" | 116 | 797 |
| DKULVNC100E | 1" | 25 | 10 | 159 | 33 | 78 | 24 | 58 | 166 | 97 | 116 | 1 1/2" | 1/4" | 121 | 1025 |
| DKULVNC114E | 1 1/4" | 32 | 10 | 163 | 30 | 82 | 24 | 72 | 194 | 97 | 134 | 2" | 1/4" | 142 | 1151 |
| DKULVNC112E | 1 1/2" | 40 | 10 | 207 | 35 | 112 | 24 | 79 | 222 | 126 | 154 | 2 1/4" | 1/4" | 162 | 2922 |
| DKULVNC200E | 2" | 50 | 10 | 245 | 46 | 142 | 24 | 98 | 266 | 157 | 184 | 2 3/4" | 1/4" | 194 | 6304 |

FKM

| Reference | d | DN | PN | B | B ₁ | C | C ₁ | E | H | H ₁ | L[5:α] | R ₁ | R[5:α] | Z | g |
|-------------|--------|----|----|-----|----------------|-----|----------------|----|-----|----------------|--------|----------------|--------|-----|------|
| DKULVNC012F | 1/2" | 15 | 10 | 148 | 25 | 66 | 24 | 41 | 131 | 97 | 90 | 1" | 1/4" | 97 | 735 |
| DKULVNC034F | 3/4" | 20 | 10 | 151 | 30 | 69 | 24 | 50 | 154 | 97 | 108 | 1 1/4" | 1/4" | 116 | 797 |
| DKULVNC100F | 1" | 25 | 10 | 159 | 33 | 78 | 24 | 58 | 166 | 97 | 116 | 1 1/2" | 1/4" | 121 | 1025 |
| DKULVNC114F | 1 1/4" | 32 | 10 | 163 | 30 | 82 | 24 | 72 | 194 | 97 | 134 | 2" | 1/4" | 142 | 1151 |
| DKULVNC112F | 1 1/2" | 40 | 10 | 207 | 35 | 112 | 24 | 79 | 222 | 126 | 154 | 2 1/4" | 1/4" | 162 | 2922 |
| DKULVNC200F | 2" | 50 | 10 | 245 | 46 | 142 | 24 | 98 | 266 | 157 | 184 | 2 3/4" | 1/4" | 194 | 6304 |

PTFE

All information subject to change.

Please contact us on <https://www.aliasis.co.uk/get-in-touch> for further informations

DKULV/CP NC – Pneumatically actuated 2-way diaphragm valve

PN 10 DN 15:65

| Reference | d | DN | PN | B | B ₁ | C | C ₁ | E | H | H ₁ | L[5:α] | R ₁ | R[5:α] | Z | g |
|-------------|-------|----|----|-----|----------------|-----|----------------|----|-----|----------------|--------|----------------|--------|-----|------|
| DKULVNC012P | 1/2" | 15 | 10 | 148 | 25 | 66 | 24 | 41 | 131 | 97 | 90 | 1" | 1/4" | 97 | 735 |
| DKULVNC034P | 3/4" | 20 | 10 | 151 | 30 | 69 | 24 | 50 | 154 | 97 | 108 | 1"1/4 | 1/4" | 116 | 797 |
| DKULVNC100P | 1" | 25 | 10 | 159 | 33 | 78 | 24 | 58 | 166 | 97 | 116 | 1"1/2 | 1/4" | 121 | 1025 |
| DKULVNC114P | 1"1/4 | 32 | 10 | 163 | 30 | 82 | 24 | 72 | 194 | 97 | 134 | 2" | 1/4" | 142 | 1151 |
| DKULVNC112P | 1"1/2 | 40 | 10 | 207 | 35 | 112 | 24 | 79 | 222 | 126 | 154 | 2"1/4 | 1/4" | 162 | 2922 |
| DKULVNC200P | 2" | 50 | 10 | 245 | 46 | 142 | 24 | 98 | 266 | 157 | 184 | 2"3/4 | 1/4" | 194 | 6304 |