

TBM PN10 SDR 11 - S 5 - Fittings equal ends

90° Tee, short spigot for butt welding PN10 SDR 11 - S 5.

Series of fittings designed for conveying fluids under pressure with a weld connection system (butt welding).

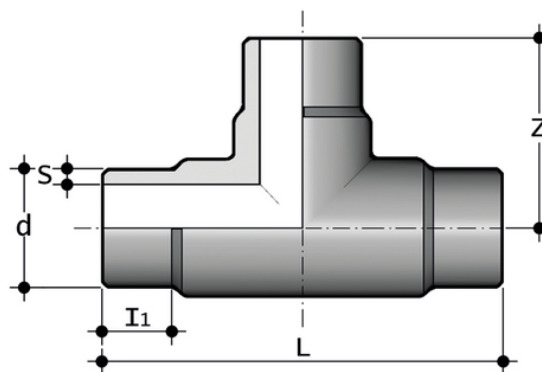

Reference	d	h ₁	L	s	Z	g
TBM11020	20	8	50	1,9	25	11
TBM11025	25	10	60	2,3	30	15
TBM11032	32	12	80	2,9	40	30
TBM11040	40	20	96	3,7	48	55
TBM11050	50	25	124	4,6	62	115
TBM11063	63	29	156	5,8	78	230
TBM11075	75	33	180	6,8	90	390
TBM11090	90	23	200	8,2	100	645
TBM11110	110	43	240	10	120	1040
TBM11125	*125	26	250	11,4	125	1480
TBM11140	*140	32	280	12,7	140	2060
TBM11160	160	40	320	14,6	160	2925
TBM11180	*180	73	390	16,4	195	4665
TBM11200	*200	64	430	18,2	215	6470
TBM11225	225	72	490	20,5	245	9220
TBM11250	*250	86	550	22,7	275	12650
TBM11280	*280	105	620	25,4	310	18205
TBM11315	*315	111	700	28,6	350	25700
TBM11355	*355	103	698	32,2	349	30200

All information subject to change.

Please contact us on <https://www.aliaxis.co.uk/get-in-touch> for further informations



TBM PN10 SDR 11 - S 5 - Fittings equal ends

Reference	d	h ₁	L	s	Z	g
TBM11400	*400	105	720	36,3	360	39100
TBM11450	*450	137	838	40,9	419	61129
TBM11500	*500	160	930	45,4	465	84230

All information subject to change.

Please contact us on <https://www.aliaxis.co.uk/get-in-touch> for further informations

