

BIFGM – Adaptor union

Union for socket welding (d), BSP (R) threaded female end with O-Ring in EPDM or FKM.

Series of fittings designed for conveying fluids under pressure with a hot thread and weld connection system (socket welding).

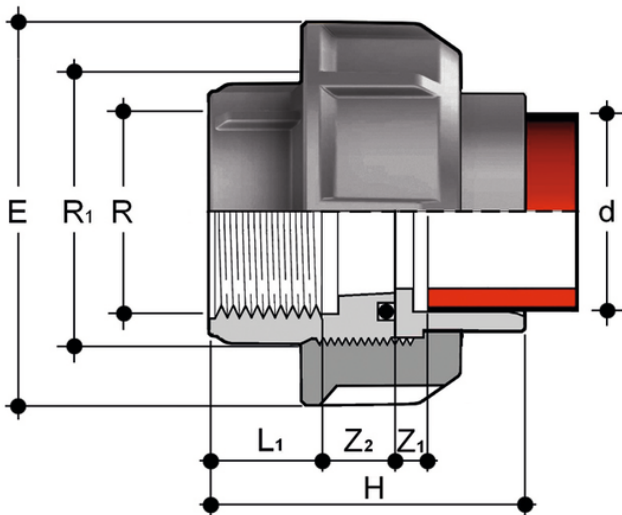

EPDM

Reference	d x R	R ₁	PN	E	H	L ₁	Z ₁	Z ₂	g
BIFGM020012E	20 x 1/2"	1"	10	47	50,5	15	5,5	16	43
BIFGM025034E	25 x 3/4"	1 1/4"	10	58	54,5	16,3	5,5	16,7	68
BIFGM032100E	32 x 1"	1 1/2"	10	65	59,5	19,1	5,5	16,9	94
BIFGM040114E	40 x 1 1/4"	2"	10	78	66,5	21,4	5,5	19,6	145
BIFGM050112E	50 x 1 1/2"	2 1/4"	10	85	73,5	21,4	5,5	23,6	196
BIFGM063200E	63 x 2"	2 3/4"	10	103	82,5	25,7	5,5	24,3	312

FKM

Reference	d x R	R ₁	PN	E	H	L ₁	Z ₁	Z ₂	g
BIFGM020012F	20 x 1/2"	1"	10	47	50,5	15	5,5	16	43
BIFGM025034F	25 x 3/4"	1 1/4"	10	58	54,5	16,3	5,5	16,7	68
BIFGM032100F	32 x 1"	1 1/2"	10	65	59,5	19,1	5,5	16,9	94
BIFGM040114F	40 x 1 1/4"	2"	10	78	66,5	21,4	5,5	19,6	145
BIFGM050112F	50 x 1 1/2"	2 1/4"	10	85	73,5	21,4	5,5	23,6	196
BIFGM063200F	63 x 2"	2 3/4"	10	103	82,5	25,7	5,5	24,3	312

All information subject to change.

Please contact us on <https://www.aliasis.co.uk/get-in-touch> for further informations