

# HIM - 45° elbow

45° elbow for socket welding.

Series of fittings designed for conveying fluids under pressure with a hot weld connection system (socket welding).

- **Size range:** d 20 ÷ d 110 (mm)
- **Nominal pressure:** PN 10 with water at 20° C
- **Temperature range:** 0 °C ÷ 100 °C
- **Coupling standards:**
  - *Welding:* EN ISO 15494. Can be coupled to pipes according to EN ISO 15494
  - *Flanging system:* ISO 7005-1, EN 1092-1, EN ISO 15494, ANSI B16.5 cl.150
- **Reference standards:**
  - *Construction criteria:* EN ISO 15494
  - *Test methods and requirements:* EN ISO 15494
  - *Installation criteria:* DVS 2202-1, DVS 2207-11, DVS 2208-1, UNI 11318
- **Fitting material:** PP-H
- **Seal material:** EPDM, FKM

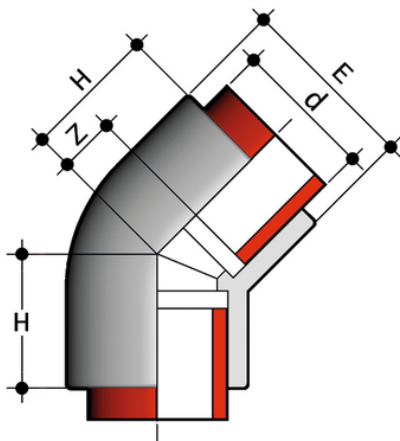

Reference	d	DN	PN	E	H	Z	g
HIM020	20	15	10	28	21	7	12
HIM025	25	20	10	34	25	9	19
HIM032	32	25	10	42	29	12	33
HIM040	40	32	10	52	36	15	57
HIM050	50	40	10	63	43	19	105
HIM063	63	50	10	79	51	24	182
HIM075	75	65	10	92	53	20	200
HIM090	90	80	10	113	61	23,5	335
HIM110	110	100	10	135	71	28	610

All information subject to change.

Please contact us on <https://www.aliasis.co.uk/get-in-touch> for further informations