

T SDR 11

Equal tee, SDR 11

Equal tee T SDR 11

- Gas, water and H2
- Working pressure: MOP (gas) 10 bar, PFA (water) 16 bar
- Material: PE 100-RC
- Safety technology
- DVGW test mark: DV-8606AU2249 and DV-8611AU2250
- FM Approvals Class: 1613 (d 75 - d 315)

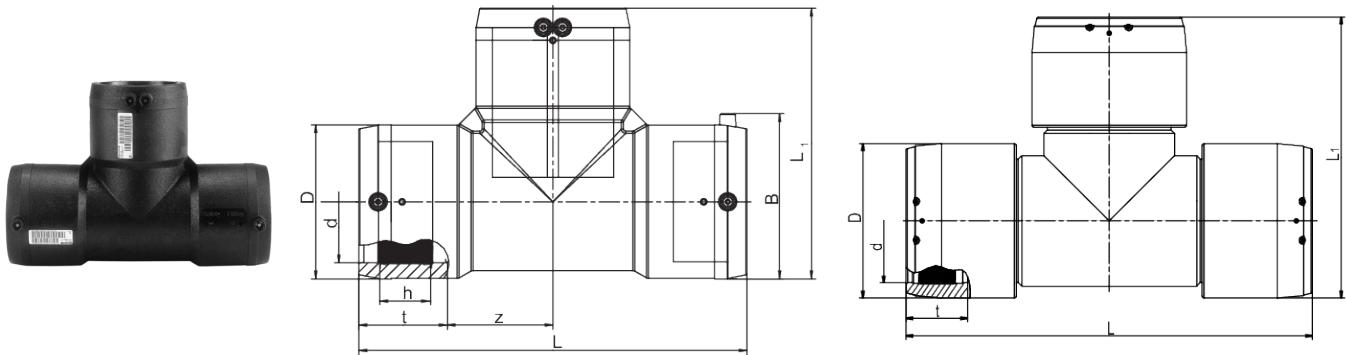

Reference	Diameter	SDR range	B	D	h	L	L1	t	z	Weight [kg]	BX	Pallet quantity
612165	75	11 - 17,6	111	96	37	278	187	62	69	0,980	8	144
612166	90	11 - 17,6	129	117	44	305	211	71	74	1,660	10	80
612167	110	11 - 17,6	152	142	48	355	248	79	91	2,590	6	48
612168	125	11 - 17,6	168	160	44	384	272	79	105	3,500	5	40
615277	160	11 - 17,6	206	200	41	430	315	88	119	5,820	3	24
615691	180	11 - 17,6	234	228	62	480	354	95	137	7,840	2	16
616266	200	11 - 17,6	255	251	54	550	400	109	160	11,130	1	8
615692	225	11 - 17,6	286	284	63	580	432	111	172	13,910	1	8
616412	250	11 - 17,6	-	310	80	770	540	128	254	28,200	1	4
616413	280	11 - 17,6	-	350	84	905	630	139	312	42,200	1	2
616414	315	11 - 17,6	-	396	80	940	670	150	359	58,100	1	1