

TFL

Tee with flanged outlet, SDR 11 / SDR 17

Tee with flanged outlet TFL

- Water
- Working pressure: PFA (water) 16 bar (SDR 11), 10 bar (SDR 17)
- Material: PE 100-RC and metal insert
- Safety technology

Note:

Reduction and fusion flange. Metal insert in flange in order to prevent cold flow.

We recommend GST seals.

Note the screw tightening torques after specifying the seal manufacturer or DVS.

Additional washers are required.

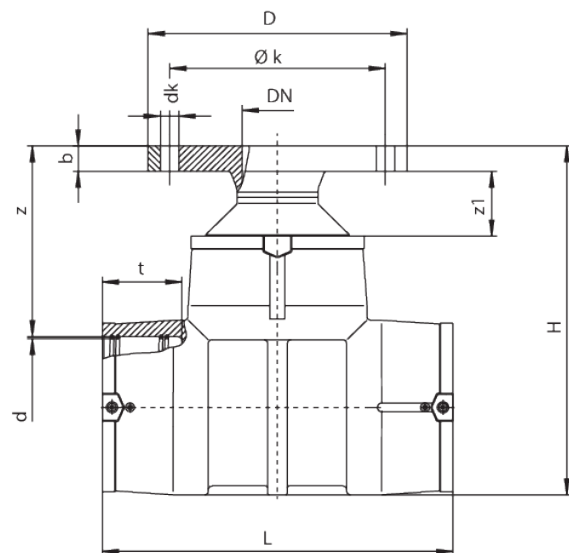

PE 100 SDR 11

Maximum permissible working pressure 16 bar (water)

Reference	Diameter	DN	SDR range	D	dk	H	k	L	t	z	z1	Weight [kg]	BX	Pallet quantity
615590	110	80	11 - 17,6	204	17	316	160	355	87	190	42	5,170	4	32
615591	125	80	11 - 17,6	204	17	343	160	384	87	190	45	5,490	3	24
615592	160	80	11 - 17,6	204	17	390	160	430	96	210	50	8,050	2	16
615910	180	80	11 - 17,6	204	17	416	160	480	103	210	-	10,000	1	8

TFL

Tee with flanged outlet, SDR 11 / SDR 17

PE 100 SDR 17

Maximum permissible working pressure 10 bar (water)

Reference	Diameter	DN	SDR range	D	dk	H	k	L	t	z	Weight [kg]	BX	Pallet quantity	
616031	225	80	11 - 17,6	204	17	465	160	580	118	210	-	15,420	2	4

Tee with flanged outlet, SDR 11 / SDR 17

Areas of Application

The FRIALEN Flange T-Piece is used for the transition between HD-PE pipes to pipes or valves made from metal. The main area of application of the FRIALEN Flange T-Piece is the hydrant connection. For a branch line in DN 80 you can flange directly a shut-off valve. Other nominal diameters can be also realised with the FRIALEN T-Piece¹⁾ in combination with FRIALEN flange reducer FLR respectively if the nominal diameter is equal with the FRIALEN Full faced flange EFL²⁾.

FRIALEN safety fittings can be fused with pipes with SDR levels 11 to 17.6. Other levels of SDR can be processed on request. Please note the mandatory labels directly on the product. DVGW test mark issued: DV-8606AU2249

Assembly Instructions

The Flange T-Piece is installed only in pressure-free condition. Please refer to the FRIALEN-Assembly Instructions with regard to the preparations of the T-Piece in the direction of the passage opening with HD-PE pipes (marking of insertion depth, removing oxide skin, cleaning, etc.) for FRIALEN fusion.

Flange connection measurements correspond to DIN EN 1092-1.

Supplementary washers are necessary.

All standard profile or flat gaskets can be used. Please observe screw torque specifications as indicated by the gasket manufacturer. We recommend G-ST gaskets.

¹⁾ see Data Sheet No. 10

²⁾ see Data Sheet No. 46

Good reasons for using the FRIALEN Flange Tee with flanged outlet:

- Compact part in HD-PE for direct connection to flanged valves and hydrants
- Factory made combination made from FRIALEN T-Piece, Reducer and Weld in flange (fixed flange)
- Optional installation position (upright or horizontal position)
- No inner fusion ridge on the fused seam of the reducer
- No "cold-flow characteristics" at the flange due to constructive design
- Short dimensions with regard to height and length
- Particularly economical solution
- T-Piece with exposed heating coils for optimal heat transfer, large insertion depth, wide fusion zones plus cold zones at the end and in the middle to prevent the flow of molten material
- Additional barcode for tracing back the underground fitting (Traceability-Coding)