

DK

Cap for tapping tees, SDR 11

Cap for tapping tees DK SDR 11

- Gas, water and H₂
- Working pressure: MOP (gas) 10 bar, PFA (water) 16 bar
- Material: PE 100-RC
- Safety technology
- DVGW test mark: DV-8601AU2248

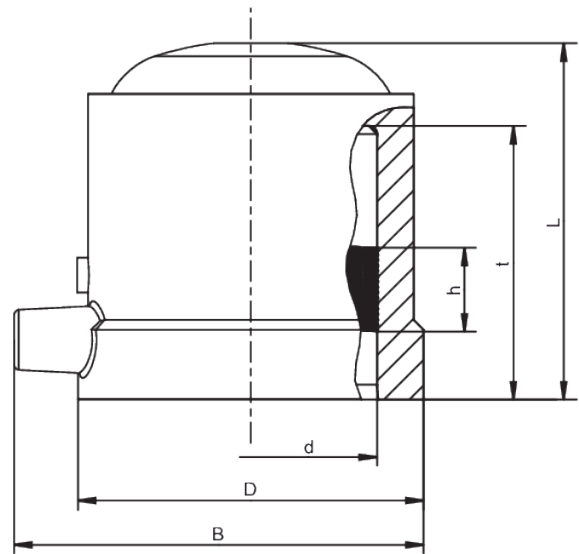

PE 100-RC SDR 11

Maximum permissible working pressure 16 bar (water) / 10 bar (gas)



Reference	Diameter	B	D	h	L	t	Weight [kg]	BX	Pallet quantity
612310	50	82	69	28	72	55	0,120	30	960

DK

Cap for tapping tees, SDR 11

Areas of Application

The FRIALEN-Cap is used for final sealing of the drill socket (dome) of a Pressure Tapping Tee DAA \geq d 90/xx or SPA d 63. Also suitable as a sealing cap for d 50 pipes.

FRIALEN safety fittings can be fused with pipes with SDR levels 11 to 17.6. Minimum wall thickness $s_{\text{minimum}} \geq 3$ mm. Other levels of SDR can be processed on request. Please note the mandatory labels directly on the product. DVGW test mark issued: DV-8601AU2248

Assembly Instructions

The fusion of the dome of a FRIALEN-Pressure Tapping Tee with the FRIALEN-Cap K takes place by FRIALEN-fusing – leakproof and longitudinally strong.

The dome is prepared according to the general installation instructions (see "Assembly Instructions" for "FRIALEN-Safety Fittings for house connections and distribution pipes up to d 225").

Good reasons for using the FRIALEN-Cap DK:

- Large insertion depth for ease of pipe guiding
- Maximum stability through great wall thickness
- Cold zones at the end to prevent the flow of molten material
- Exposed heating coils for optimal heat transfer to the pipe
- Small annular gap for build-up of optimum joining pressure in the fusion zone
- Contacts safe to touch
- Durable batch marking
- Individually wrapped for dirt protection
- Additional barcode for tracing back the fitting (Traceability-Coding)