

FRIALOC

PE shut-off valve without flow losses

Shut-off valve FRIALOC CW

- Water
- Working pressure: PFA (water) 16 bar
- Material: PE 100
- Wrench size SW19 (19 mm)
- Double shut-off function
- No cavities and stagnation
- No flow losses
- Maximum 14 turns for opening and closing
- DVGW test mark: DW-6210BT0171

Note:

The dimension d 200 to d250 have a restricted passage of d 180.

There is a suitable installation kit FBS with KlickFix for wrench size SW19 (19 mm).

Value da is the maximum tapping diameter of the external tapping device.

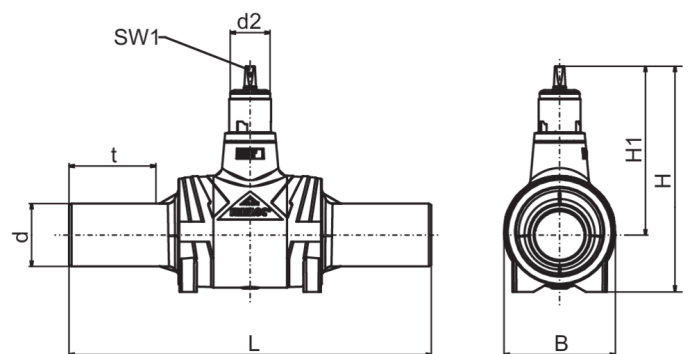

PE 100 SDR 11

Maximum permissible working pressure 16 bar (water)



Reference	Diameter	d ₂	B	H	H ₁	L	t	SW1	Turns open/close	Weight [kg]	BX	Pallet quantity
616293	90	80	225	450	335	720	158	19	9	13,900	1	8
616294	110	80	225	450	335	720	164	19	9	14,200	1	8
616295	125	80	225	450	335	720	174	19	9	14,500	1	8
616296	160	80	330	608	450	1010	196	19	14	37,900	1	2
616297	180	80	330	608	450	1030	210	19	14	39,000	1	2
616453	200	80	330	608	450	1030	120	19	14	40,500	1	2

FRIALOC

PE shut-off valve without flow losses

Reference	Diameter	d ₂	B	H	H1	L	t	SW1	Turns open/close	Weight [kg]	BX	Pallet quantity
616298	225	80	330	608	450	1030	124	19	14	40,500	1	2
616438	250	80	330	608	450	1030	132	19	14	41,940	1	2

FRIALOC

PE shut-off valve without flow losses

Range of use / application

FRIALOC is used as shut-off valve in water piping systems. The free passage of the PE shut-off valve shows no

constrictions with regard to the connecting pipe SDR 11. Actuation is made from the street cap using the installation kit FBS. Thanks to the innovative shut-off mechanism, activation is possible with only a few turns and without major force. For further information see this data sheet page 2 or data sheet installation kit FBS No. 63/07.

DVGW test mark issued: DW-6210BT0171. Please note the mandatory labels directly on the product.

d_G : max. tapping diameter of the external tapping device

Notes on processing

The FRIALOC shut-off valve made of polyethylene is homogeneously connected to the PE piping by FRIALEN fusion using FRIALEN safety fittings. This requires no gaskets, material transitions, or mechanical connections. The homogeneous joint is permanently leak-tight and friction-locked. Corrosion protection is not required. The shut-off valve can also be integrated into existing piping networks made of other materials, e.g. using flanges.

Please observe the notes on the installation of the FRIALOC shut-off valve in the FRIALEN assembly instructions for house service and supply pipings up to d 225.

Good reasons for using the FRIALOC:

- FRIALOC facilitates the completely fused and homogeneous PE piping without flanges and material transitions
- Typically PE: no corrosion, no incrustation
- Innovative two-flap mechanism for a reliable shut-off under all operating conditions
- Low-wear drive: proven in fatigue test by 2,500 dynamic test cycles under maximum pressure
- Hygiene: no stagnating water, minimised sealing area
- Corrosion-resistant metal materials
- Significant weight saving compared to metal valves
- Special contour for a pull-tight and dirt-proof connection to the protective pipe of the FRIALEN FBS
- Low actuation forces, smooth-running even given under full differential pressure
- Few turns for opening/closing
- Optimal hydraulics thanks to a full-port passage, no constrictions
- Stable support in the ditch bottom thanks to large support area
- Length of connecting d 90-d 180 couplers designed for two fusion processes, can be reduced for compact shape
- Each single shut-off valve is inspected by the factory after mounting
- Production data are saved, archived, and can be documented via a traceability barcode