

# RS TL

## Repair saddle for top loading, SDR11

Repair saddle Top-Loading RS TL SDR 11

- Gas, water and H2
- Working pressure: MOP (gas) 10 bar, PFA (water) 16 bar
- Material: PE 100-RC
- Universal clamping option (top loading):
  - Safe clamping with FRIATOP
  - Universal adaptation to pipe diameter
- Safety technology
- DVGW test mark: DV-8611AU2250

**Note:**

Can only be used with the clamping device FRIATOP (Order No. 613350).

Only apply to minor pipe damage.

The damage must be located within the repair area and not in the fusion zone.

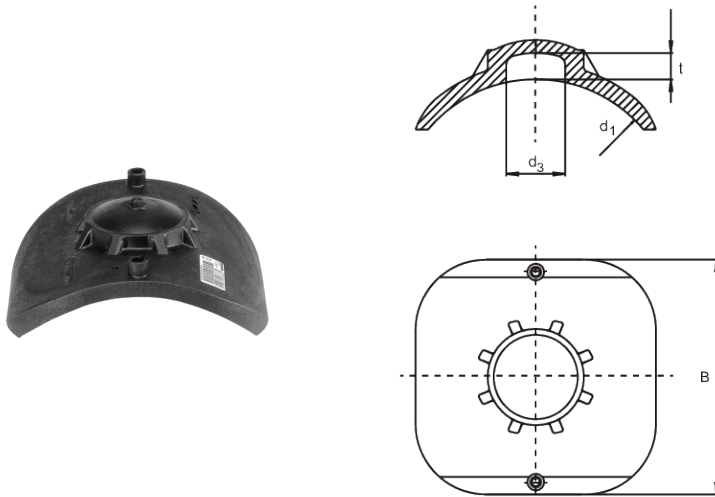

Reference	d <sub>1</sub>	B	D <sub>1</sub>	d <sub>3</sub>	t	Weight [kg]	BX	Pallet quantity
615397	250-560	200	250-560	50	20	0,580	10	180