

RV DN 15÷100

Sediment strainer



RV DN 15÷100

The RV Sediment strainer limits the passage of any solid particles present in the fluid by means of a strainer.

SEDIMENT STRAINER

- Connection system for weld, threaded and flanged joints
- **Strainer** assembled on an **easily removed support** that facilitates cleaning or replacement
- **Valve material compatibility** (PP-H) with water conveyance, drinking water and other food substances according to **current regulations**
- Can be maintained with the valve body installed

Technical specifications	
Construction	Sediment strainer
Size range	DN 15 ÷ 100
Nominal pressure	DN 15÷50: PN 10 with water at 20° C DN 65: PN 6 with water at 20° C DN 80÷100: PN 4 with water at 20° C
Temperature range	0 °C ÷ 100 °C
Coupling standards	Welding: EN ISO 15494. Can be coupled to pipes according to EN ISO 15494 Thread: UNI ISO 228-1, EN 10226-1/2 Flanging system: ISO 9624, EN ISO 1092-1, EN ISO 15494, EN 558-1, ANSI B.16.5 cl. 150
Reference standards	Construction criteria: EN ISO 15494 Test methods and requirements: ISO 9393 Installation criteria: EN 14728, DVS 2207-11, DVS 2208-1, UNI 11318
Valve material	Body: PP-H Strainer: PP
Seal material	EPDM, FKM

TECHNICAL DATA

PRESSURE VARIATION ACCORDING TO TEMPERATURE

For water and non-hazardous fluids with regard to which the material is classified as CHEMICALLY RESISTANT. In other cases, a reduction of the nominal pressure PN is required (25 years with safety factor).

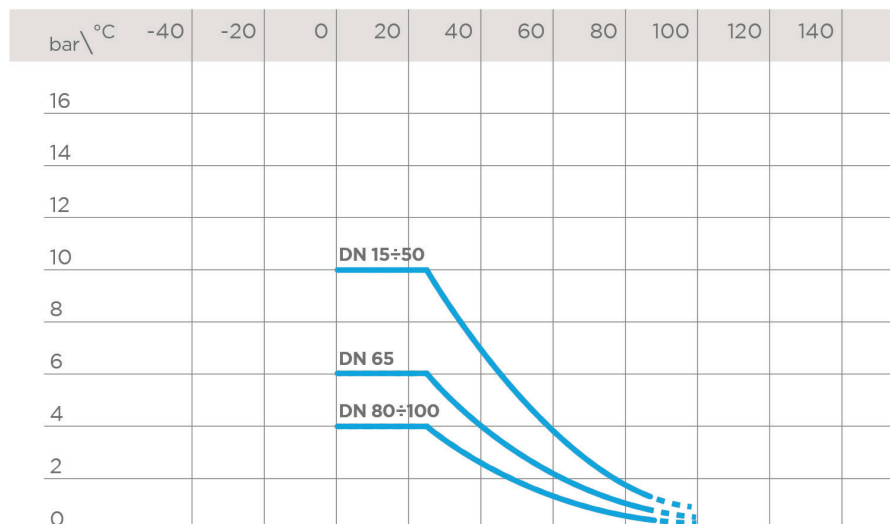

PRESSURE DROP GRAPH

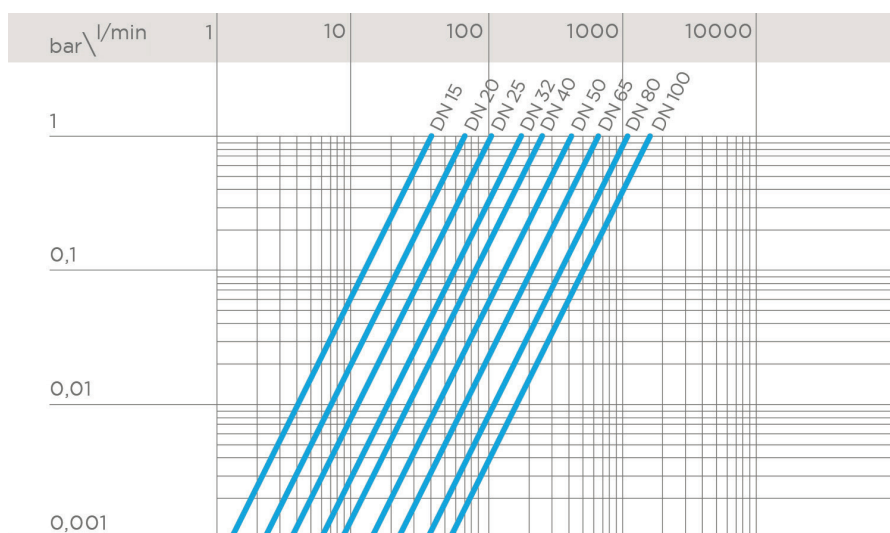

K_v100 FLOW COEFFICIENT

The K_v100 flow coefficient is the Q flow rate of litres per minute of water at a temperature of 20°C that will generate Δp= 1 bar pressure drop at a certain valve position. The Kv100 values shown in the table are calculated with the valve completely clean.

DN	15	20	25	32	40	50	65	80	100
Kv100 l/min	40	70	103	188	255	410	650	1050	1700

STRAINER DIMENSIONS

DN	15÷20	25÷100
number of holes per cm ²	37	32
ASTM series equivalent in strainer	18	20
ø equivalent hole μm	1016	889
strainer material	PP	PP

TOTAL STRAINER AREA A_{TOT} (CM²)

DN	15	20	25	32	40	50	65	80	100
A_{tot}	16	23,5	36	53	69	101	197	247	396

The information in this leaflet is provided in good faith. No liability will be accepted concerning technical data that is not directly covered by recognised international standards. FIP reserves the right to carry out any modification. Products must be installed and maintained by qualified personnel.

DIMENSIONS

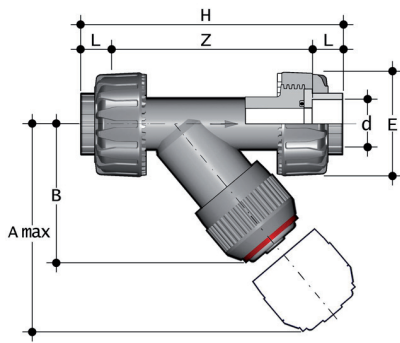

RVUIM

Sediment strainer with female union ends for socket welding, metric series

d	DN	PN	A max	B	E	H	Z	Fig.	g	EPDM code	FKM code
20	15	10	125	71	55	138	109	A	148	RVUIM020E	RVUIM020F
25	20	10	145	83	66	157	125	A	195	RVUIM025E	RVUIM025F
32	25	10	165	94	74	179	143	A	297	RVUIM032E	RVUIM032F
40	32	10	190	109	86	205	164	A	475	RVUIM040E	RVUIM040F
50	40	10	210	119	99	244	197	A	675	RVUIM050E	RVUIM050F
63	50	10	240	142,5	120	294	239	A	1100	RVUIM063E	RVUIM063F

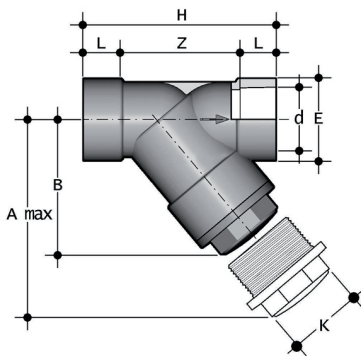

RVIM

Sediment strainer with female ends for socket welding, metric series

d	DN	PN	A max	B	E	H	K	Z	Fig.	g	EPDM code	FKM code
75	65	6	300	176	103	241	96	179	B	1580	RVIM075E	RVIM075F
90	80	4	325	193	115	260	105	189	B	1920	RVIM090E	RVIM090F
110	100	4	385	229	138	323	-	240	C	3000	RVIM110E	RVIM110F

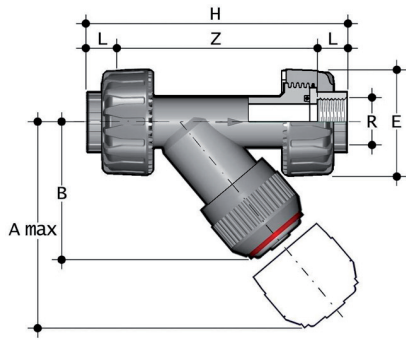

RVUFM

Sediment strainer with BSP threaded female union ends

R	DN	PN	A max	B	E	H	Z	Fig.	g	EPDM code	FKM code
1/2"	15	10	125	71	55	142	112	A	148	RVUFM012E	RVUFM012F
3/4"	20	10	145	83	66	159	126	A	195	RVUFM034E	RVUFM034F
1"	25	10	165	94	74	183	145	A	297	RVUFM100E	RVUFM100F
1" 1/4	32	10	190	109	86	214	171	A	475	RVUFM114E	RVUFM114F
1" 1/2	40	10	210	119	99	235	192	A	675	RVUFM112E	RVUFM112F
2"	50	10	240	143	120	285	234	A	1100	RVUFM200E	RVUFM200F

Note 1: The sediment strainer RVUFM/FKM might be supplied in RVUJM/FKM version with 2 threaded sockets included

Note 2: Standard filter screen is in PP-H, pitch 1,5 mm

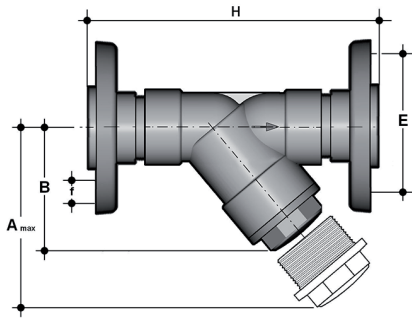

RVOM

Sediment strainer with steel core backing ring , PP/FRP coated, drilled EN/ISO/DIN PN10/16

d	DN	PN	A max	B	F	f	H	g	EPDM code	FKM code
75	65	6	300	176	145	18	356	5120	RVOM075E	RVOM075F
90	80	4	325	192	160	18	404	6020	RVOM090E	RVOM090F
110	100	4	385	231	180	18	475	7965	RVOM110E	RVOM110F

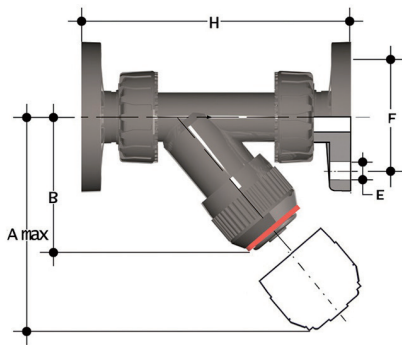

RVUOAM

Sediment strainer with female union ends and fixed flanges, drilled ANSI B16.5 cl.150 #FF

d	DN	PN	A max	B	F	f	H	g	EPDM code	FKM code
1/2"	15	10	125	72	60	16	175	248	RVUOAM012E	RVUOAM012F
3/4"	20	10	145	84	70	16	214	295	RVUOAM034E	RVUOAM034F
1"	25	10	165	95	79	16	237	397	RVUOAM100E	RVUOAM100F
1 1/4"	32	10	190	111	89	16	253	625	RVUOAM114E	RVUOAM114F
1 1/2"	40	10	210	120	98	16	289	825	RVUOAM112E	RVUOAM112F
2"	50	10	240	139	121	19	333	1250	RVUOAM200E	RVUOAM200F

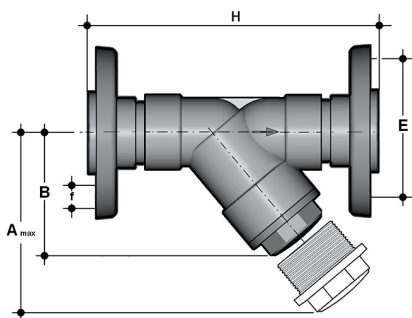

RVOAM

Sediment strainer with steel core backing ring , PP/FRP coated, drilled ANSI B16.5 cl.150 #FF

d - Size	DN	PN	A max	B	F	f	H	g	EPDM code	FKM code
75 - 2 1/2"	65	6	300	179	139,7	18	356	4725	RVOAM212E	RVOAM212F
90 - 3"	80	4	325	192	152,4	18	404	5175	RVOAM300E	RVOAM300F
110 - 4"	100	4	385	231	190,5	18	475	7405	RVOAM400E	RVOAM400F

COMPONENTS

EXPLODED VIEW

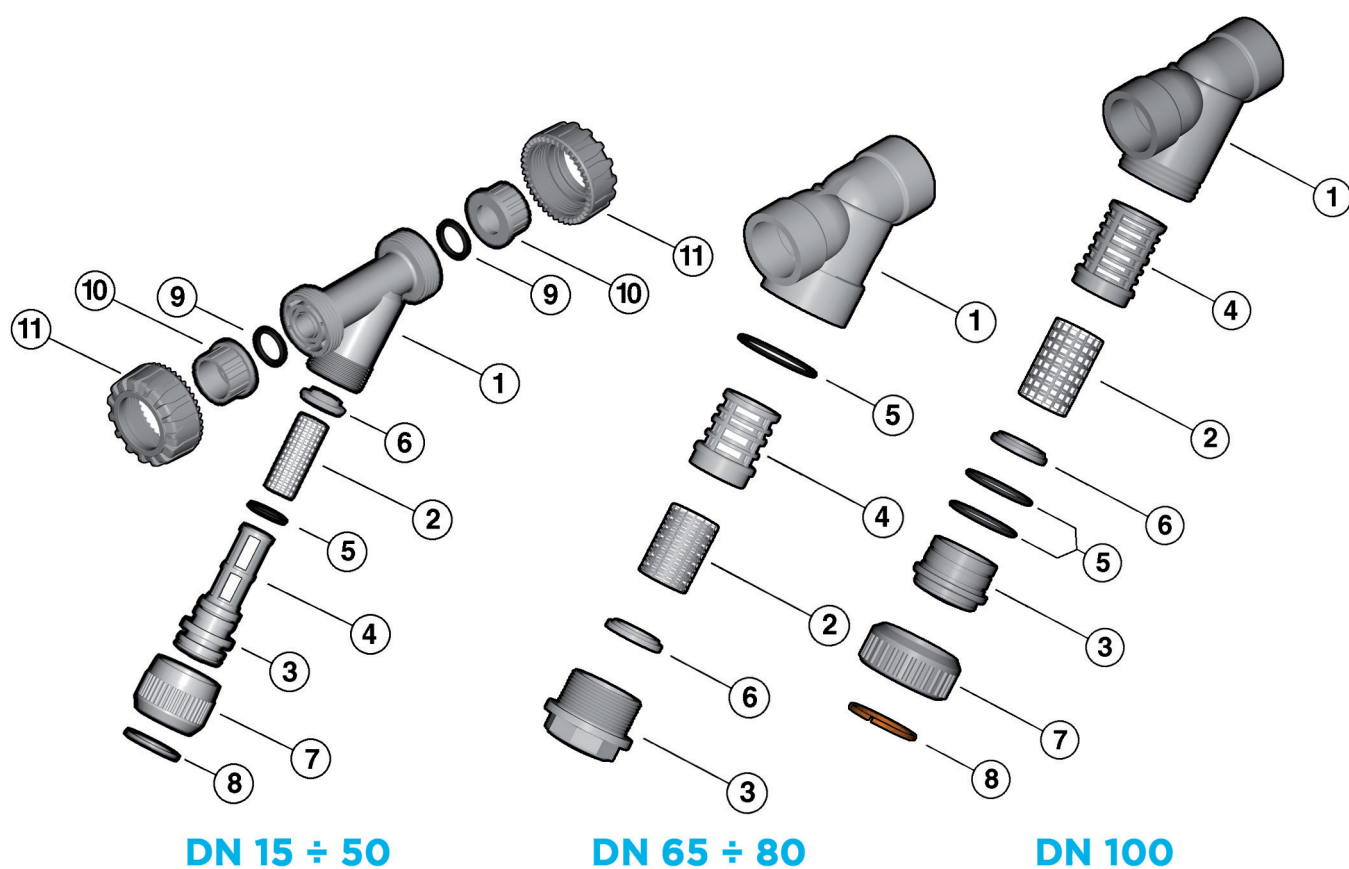

- | | | | | | |
|----------|-----------------------------|------------|---------------------------|-----------|---------------------------------------|
| 1 | Body (PP-H - 1) | 5 | O-Ring (EPDM or FKM - 1)* | 8 | Retaining ring (PP-H - 1) |
| 2 | Strainer (PP-H - 1)* | A-B | | 9 | Socket seal O-Ring (EPDM or FKM - 2)* |
| 3 | Bonnet (PP-H - 1) | 5 C | O-Ring (EPDM or FKM - 2)* | 10 | End connector (PP-H - 2)* |
| 4 | Strainer support (PP-H - 1) | 6 | Washer (PP-H - 1) | 11 | Union nut (PP-H - 2) |
| | | 7 | Union nut (PP-H - 1) | | |

* Spare parts
The material of the component and the quantity supplied are indicated between brackets

DISASSEMBLY

DN 15÷50 (FIG. A) - DN 100 (FIG. C)

- 1) Isolate the sediment strainer from the fluid flow and empty the system upstream.
- 2) Unscrew the union nut (7) and separate the bonnet-support (3-4) from the body (1).
- 3) Remove the bottom washer (6) from the bonnet-support (3-4).
- 4) Remove the retaining ring (8) and separate the union nut (7) from the bonnet (3).
- 5) Remove the O-Ring from the bonnet (5).

DN 65÷80 (FIG. B)

- 1) Isolate the sediment strainer from the fluid flow and empty the system upstream.
- 2) Unscrew the bonnet (3) and separate it from the body (1).
- 3) Remove the support (4) from the bonnet (3).
- 4) Remove the washer (6) from the bonnet (3) and the O-Ring (5) from its seating in the body.

ASSEMBLY

DN 15÷50 (FIG. A) - DN 100 (FIG. C)

- 1) Insert the O-Ring (5) in its seating in the bonnet (3).
- 2) Insert the bonnet (3) in union nut (7) and fix the two components using the retaining ring (8).
- 3) Insert the strainer (2) in the bonnet support (3-4) and hold in place with the washer (6).
- 4) Insert the bonnet (3) in the body (1) and tighten the union nut (7).

DN 65÷80 (FIG. B)

- 1) Insert the O-Ring (5) in the body (1)
- 2) Insert the washer (6) in the bonnet (3)
- 3) Insert the strainer (2) in its support (4)
- 4) Insert the support (4) in the bonnet (3)
- 5) Screw the bonnet (3) in the body (1)



Note: maintenance operations can be carried out with the valve body installed. During assembly, it is advisable to lubricate the rubber seals. Mineral oils are not recommended for this task as they react aggressively with EPDM rubber.

Fig. A

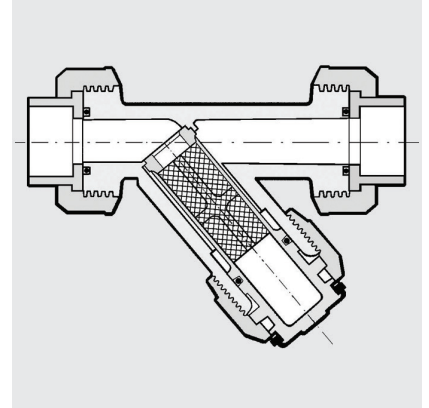

Fig. B

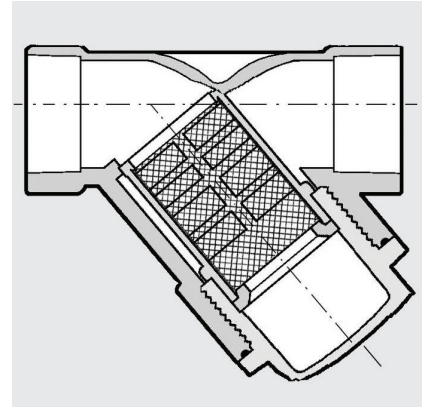
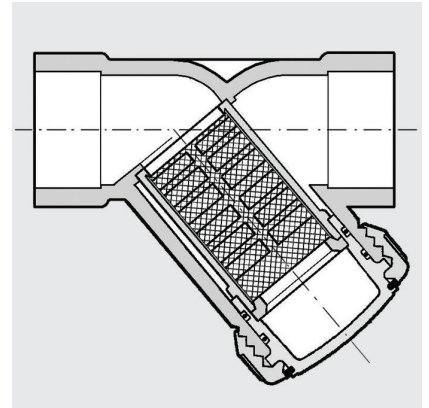

Fig. C



INSTALLATION

DN 15÷50 (fig. A)

The sediment strainer can be installed in any position, making sure that the arrow stamped on the body indicates the direction of fluid flow and that the strainer part is facing downwards. To avoid damaging the strainer, appropriate devices must be installed on the line to prevent backflow.

- 1) Unscrew the union nuts (11) and slide them onto the pipe.
- 2) Heat weld the end connectors (10) onto the pipe segments.
- 3) Position the sediment strainer between the end connectors
- 4) Tighten the union nuts.

DN 65÷80 (fig. B) e DN 100 (fig. C)

The joint must be made by solvent welding the pipe directly into the socket of the valve body.

WARNINGS

- Always check the cleanliness of the filter elements.